



Operating Instructions and Parts Manual

10-inch ProShop™ Table Saw with Riving Knife

Model JPS-10TS



(shown with steel wings and 30" rail set)

for serial no. 14053173 and higher

JET
427 New Sanford Road
LaVergne, Tennessee 37086
Ph.: 800-274-6848
www.jettools.com



Part No. M-708490
Revision C 05/2014
Copyright © 2014 JET

1.0 Warranty and Service

JET warrants every product it sells against manufacturers' defects. If one of our tools needs service or repair, please contact Technical Service by calling 1-800-274-6846, 8AM to 5PM CST, Monday through Friday.

Warranty Period

The general warranty lasts for the time period specified in the literature included with your product or on the official JET branded website.

- JET products carry a limited warranty which varies in duration based upon the product. (See chart below)
- Accessories carry a limited warranty of one year from the date of receipt.
- Consumable items are defined as expendable parts or accessories expected to become inoperable within a reasonable amount of use and are covered by a 90 day limited warranty against manufacturer's defects.

Who is Covered

This warranty covers only the initial purchaser of the product from the date of delivery.

What is Covered

This warranty covers any defects in workmanship or materials subject to the limitations stated below. This warranty does not cover failures due directly or indirectly to misuse, abuse, negligence or accidents, normal wear-and-tear, improper repair, alterations or lack of maintenance.

Warranty Limitations

Woodworking products with a Five Year Warranty that are used for commercial or industrial purposes default to a Two Year Warranty. Please contact Technical Service at 1-800-274-6846 for further clarification.

How to Get Technical Support

Please contact Technical Service by calling 1-800-274-6846. **Please note that you will be asked to provide proof of initial purchase when calling.** If a product requires further inspection, the Technical Service representative will explain and assist with any additional action needed. JET has Authorized Service Centers located throughout the United States. For the name of an Authorized Service Center in your area call 1-800-274-6846 or use the Service Center Locator on the JET website.

More Information

JET is constantly adding new products. For complete, up-to-date product information, check with your local distributor or visit the JET website.

How State Law Applies

This warranty gives you specific legal rights, subject to applicable state law.

Limitations on This Warranty

JET LIMITS ALL IMPLIED WARRANTIES TO THE PERIOD OF THE LIMITED WARRANTY FOR EACH PRODUCT. EXCEPT AS STATED HEREIN, ANY IMPLIED WARRANTIES OF MERCHANTABILITY AND FITNESS FOR A PARTICULAR PURPOSE ARE EXCLUDED. SOME STATES DO NOT ALLOW LIMITATIONS ON HOW LONG AN IMPLIED WARRANTY LASTS, SO THE ABOVE LIMITATION MAY NOT APPLY TO YOU.

JET SHALL IN NO EVENT BE LIABLE FOR DEATH, INJURIES TO PERSONS OR PROPERTY, OR FOR INCIDENTAL, CONTINGENT, SPECIAL, OR CONSEQUENTIAL DAMAGES ARISING FROM THE USE OF OUR PRODUCTS. SOME STATES DO NOT ALLOW THE EXCLUSION OR LIMITATION OF INCIDENTAL OR CONSEQUENTIAL DAMAGES, SO THE ABOVE LIMITATION OR EXCLUSION MAY NOT APPLY TO YOU.

JET sells through distributors only. The specifications listed in JET printed materials and on official JET website are given as general information and are not binding. JET reserves the right to effect at any time, without prior notice, those alterations to parts, fittings, and accessory equipment which they may deem necessary for any reason whatsoever. JET® branded products are not sold in Canada by JPW Industries, Inc.

Product Listing with Warranty Period

90 Days – Parts; Consumable items; Light-Duty Air Tools
1 Year – Motors; Machine Accessories; Heavy-Duty Air Tools; Pro-Duty Air Tools
2 Year – Metalworking Machinery; Electric Hoists, Electric Hoist Accessories
5 Year – Woodworking Machinery
Limited Lifetime – JET Parallel clamps; VOLT Series Electric Hoists; Manual Hoists; Manual Hoist Accessories; Shop Tools; Warehouse & Dock products; Hand Tools

NOTE: JET is a division of JPW Industries, Inc. References in this document to JET also apply to JPW Industries, Inc., or any of its successors in interest to the JET brand.

2.0 Table of contents

Section	Page
1.0 Warranty and Service	2
2.0 Table of contents	3
3.0 Safety warnings	4
3.1 Kickback	5
4.0 About this manual	6
5.0 Glossary	7
6.0 Features	8
7.0 Specifications	8
8.0 Setup and assembly	10
8.1 Shipping contents.....	10
8.2 Unpacking and cleanup	11
8.3 Installing legs	11
8.4 Handwheels	11
8.5 Extension wings	12
8.6 Extension wing adjustment.....	12
8.7 Rails and fence	12
8.8 Wood extension table.....	12
8.9 Switch bracket.....	12
8.10 Dust Hood.....	12
8.11 Riving knife	13
8.12 Anti-kickback pawls	13
8.13 Blade guard.....	14
8.14 Blade installation/replacement.....	14
8.15 Aligning blade guard and riving knife	15
8.16 Low profile riving knife	15
8.17 Table insert	15
8.18 Miter gauge	15
9.0 Electrical connections	16
9.1 Grounding instructions.....	16
9.2 Voltage conversion.....	16
9.3 Overload reset button.....	17
9.4 Extension cords.....	17
9.5 On-off switch padlock	17
10.0 Adjustments.....	17
10.1 Blade raising/tilt mechanism	17
10.2 Adjusting 45° and 90° positive stops	17
10.3 Table to blade alignment	19
10.4 Belt adjustment and replacement.....	19
11.0 Operations.....	20
12.0 Safety devices	24
13.0 Maintenance	25
14.0 Optional accessories.....	26
15.0 Troubleshooting the JPS-10TS	27
16.0 Replacement Parts	27
16.1.1 Motor and Trunnion – Exploded View	28
16.1.2 Motor and Trunnion – Parts List.....	29
16.2.1 Table and Cabinet – Exploded View	32
16.2.2 Table and Cabinet – Parts List.....	33
16.3.1 Stand Assembly – Exploded View.....	35
16.3.2 Stand Assembly – Parts List.....	35
16.4.1 Cast Iron Wings – Exploded View.....	36
16.4.2 Cast Iron Wings – Parts List	36
17.1 Electrical Connections – 115V.....	37
17.2 Electrical Connections – 230V.....	38



3.0 Safety warnings

1. Read and understand the entire owner's manual before attempting assembly or operation.
 2. Read and understand the warnings posted on the machine and in this manual. Failure to comply with all of these warnings may cause serious injury.
 3. Replace the warning labels if they become obscured or removed.
 4. This table saw is designed and intended for use by properly trained and experienced personnel only. If you are not familiar with the proper and safe operation of a table saw, do not use until proper training and knowledge have been obtained.
 5. Do not use this table saw for other than its intended use. If used for other purposes, JET disclaims any real or implied warranty and holds itself harmless from any injury that may result from that use.
 6. Always wear approved safety glasses/face shields while using this table saw. Everyday eyeglasses only have impact resistant lenses; they are not safety glasses.
 7. Before operating this table saw, remove tie, rings, watches and other jewelry, and roll sleeves up past the elbows. Remove all loose clothing and confine long hair. Non-slip footwear or anti-skid floor strips are recommended. Do not wear gloves.
 8. Always use the blade guard on all "through-sawing" operations. A through-sawing operation is one in which the blade cuts completely through the workpiece.
 9. Kickback occurs when the workpiece is thrown towards the operator at a high rate of speed. If you do not have a clear understanding of kickback and how it occurs, DO NOT operate this table saw!
 10. Wear ear protectors (plugs or muffs) during extended periods of operation.
 11. Some dust created by power sanding, sawing, grinding, drilling and other construction activities contain chemicals known to cause cancer, birth defects or other reproductive harm. Some examples of these chemicals are:
 - Crystalline silica from bricks, cement and other masonry products.
 - Arsenic and chromium from chemically treated lumber.
- Your risk of exposure varies, depending on how often you do this type of work. To reduce your exposure to these chemicals, work in a well-ventilated area and work with approved safety equipment, such as face or dust masks that are specifically designed to filter out microscopic particles.
12. Do not operate this machine while tired or under the influence of drugs, alcohol or any medication.
 13. Make certain the switch is in the OFF position before connecting the machine to the power supply.
 14. Make certain the machine is properly grounded.
 15. Make all machine adjustments or maintenance with the machine unplugged from the power source.
 16. Remove adjusting keys and wrenches. Form a habit of checking to see that keys and adjusting wrenches are removed from the machine before turning it on.
 17. Keep safety guards in place at all times when the machine is in use. If removed for maintenance purposes, use extreme caution and replace the guards immediately after completion of maintenance.
 18. Check damaged parts. Before further use of the machine, a guard or other part that is damaged should be carefully checked to determine that it will operate properly and perform its intended function. Check for alignment of moving parts, binding of moving parts, breakage of parts, mounting and any other conditions that may affect its operation. A guard or other part that is damaged should be properly repaired or replaced.
 19. Provide for adequate space surrounding work area and non-glare, overhead lighting.
 20. Keep the floor around the machine clean and free of scrap material, oil and grease.
 21. Keep visitors a safe distance from the work area. Keep children away.
 22. Make your workshop child proof with padlocks, master switches or by removing starter keys.

23. Give your work undivided attention. Looking around, carrying on a conversation and “horse-play” are careless acts that can result in serious injury.
24. Maintain a balanced stance at all times so that you do not fall into the blade or other moving parts. Do not overreach or use excessive force to perform any machine operation.
25. Use the right tool at the correct speed and feed rate. Do not force a tool or attachment to do a job for which it was not designed. The right tool will do the job better and more safely.
26. Use recommended accessories; improper accessories may be hazardous.
27. Maintain tools with care. Keep saw blades sharp and clean for the best and safest performance. Follow instructions for lubricating and changing accessories.
28. Turn off the machine before cleaning. Use a brush or compressed air to remove chips or debris — do not use your hands.
29. Do not stand on the machine. Serious injury could occur if the machine tips over.
30. Never leave the machine running unattended. Turn the power off and do not leave the machine until it comes to a complete stop.
31. Remove loose items and unnecessary work pieces from the area before starting the machine.
32. Keep hands out of the line of saw blade.
33. Use a push-stick when required.
34. Pay particular attention to instructions on reducing risk of kickback.
35. Do not perform any operation freehand.
36. Never reach around or over saw blade.
37. Don't use in dangerous environment. Don't use power tools in damp or wet location, or expose them to rain. Keep work area well lighted.

3.1 Kickback

The most common accidents among table saw users, according to statistics, can be linked to kickback, the high-speed expulsion of material from the table that can strike the operator.

Kickback can also result in the operator's hands being pulled into the blade.

Kickback Prevention

Tips to avoid the most common causes of kickback:

- Make sure the riving knife is always aligned with the blade. A workpiece can bind or stop the flow of the cut if the riving knife is misaligned, and result in kickback.
- Use a riving knife during every cut. The riving knife maintains the kerf in the workpiece, which will reduce the chance of kickback.
- Never attempt freehand cuts. The workpiece must be fed parallel to the blade, otherwise kickback will likely occur. Always use the rip fence or miter gauge to support the workpiece.
- Make sure that rip fence is parallel to blade. If not, the chances of kickback are very high. Take the time to check and adjust the rip fence.
- Feed cuts through to completion. Anytime you stop feeding a workpiece that is in the middle of a cut, the chance of binding, resulting in kickback, is greatly increased.

Protection Tips from Kickback

Kickback can happen even if precautions are taken to prevent it. Listed below are some tips to protect you if kickback *does* occur:

- Stand to the side of the blade when cutting. An ejected workpiece usually travels directly in front of the blade.
- Wear safety glasses or a face shield. Your eyes and face are the most vulnerable part of your body.
- Never place your hand behind the blade. If kickback occurs, your hand will be pulled into the blade.
- Use a push stick to keep your hands farther away from the moving blade. If a kickback occurs, the push stick will most likely take the damage that your hand would have received.

Familiarize yourself with the following safety notices used in this manual:

⚠CAUTION This means that if precautions are not heeded, it may result in minor injury and/or possible machine damage.

⚠WARNING This means that if precautions are not heeded, it may result in serious injury or possibly even death.

4.0 About this manual

This manual is provided by JET covering the safe operation and maintenance procedures for a JET Model JPS-10TS ProShop™ Table Saw. This manual contains instructions on installation, safety precautions, general operating procedures, maintenance instructions and parts breakdown. Your machine has been designed and constructed to provide years of trouble-free operation if used in accordance with the instructions as set forth in this document.

This manual is not intended to be an exhaustive guide to table saw operational methods, use of jigs or after-market accessories, choice of stock, etc. Additional knowledge can be obtained from experienced users or trade articles. Whatever accepted methods are used, always make personal safety a priority.

If there are questions or comments, please contact your local supplier or JET. JET can also be reached at our web site: www.jettools.com.

Retain this manual for future reference. If the machine transfers ownership, the manual should accompany it.

⚠WARNING **Read and understand the entire contents of this manual before attempting assembly or operation! Failure to comply may cause serious injury!**

5.0 Glossary

Arbor: Metal shaft that connects the drive mechanism to the blade.

Bevel Edge Cut: Tilt of the saw arbor and blade between 0° and 45° to perform an angled cutting operation.

Blade Guard: Mechanism mounted over the saw blade to prevent accidental contact with the cutting edge.

Crosscut: Sawing operation in which the miter gauge is used to cut across the grain of the workpiece.

Dado Blade: Blade(s) used for cutting grooves and rabbets. A stacked dado set can be used for wider grooves.

Dado Cut: Flat bottomed groove in the face of the workpiece made with a dado blade.

Featherboard: Device used to keep a board against the rip fence or table that allows the operator to keep hands away from saw blade.

Freehand: Moving the workpiece into the blade using only the hands, without a fixed positioning device. (This is a dangerous, unacceptable procedure – **always** use appropriate devices to feed the workpiece through the saw blade during cutting operations.)

Kerf: The resulting cut or gap made by a saw blade.

Kickback: An event in which the workpiece is lifted up and thrown back toward an operator, caused when a workpiece binds on the saw blade or between the blade and rip fence (or other fixed object). To minimize or prevent injury from kickbacks, see the *Operations* section.

Miter Gauge: A component that controls the workpiece movement while performing a crosscut of various angles.

Non-Through Cut: A sawing operation that requires the removal of the blade guard and standard riving knife, resulting in a cut that does not protrude through the top of the workpiece (includes Dado and rabbet cuts).

The blade guard and riving knife must be re-installed after performing a non-through cut to avoid accidental contact with the saw blade during operation.

Parallel: Position of the rip fence equal in distance at every point to the side face of the saw blade.

Perpendicular: 90° (right angle) intersection or position of the vertical and horizontal planes such as the position of the saw blade (vertical) to the table surface (horizontal).

Push Board/Push Stick: An instrument used to safely push the workpiece through the cutting operation.

Rabbet: A cutting operation that creates an L-shaped channel along the edge of the board.

Rip Cut: A cut made along the grain of the workpiece.

Riving Knife: A metal plate fixed relative to the blade, which moves with the blade as cutting depth is adjusted. Thus, it maintains not only the kerf opening in the workpiece, but also the knife-to-blade distance. A *low-profile* riving knife is used when performing a non-through cut because it sits lower than the top edge of the blade.

Splitter (Spreader): A stationary metal plate to which the blade guard is attached that maintains the kerf opening in the workpiece when performing a cutting operation.

Standard Kerf: 1/8" gap made with a standard blade.

Straightedge: A tool used to check that a surface is flat or parallel.

Through Sawing: A sawing operation in which the workpiece thickness is completely sawn through. Proper blade height usually allows 1/8" of the top of blade to extend above the wood stock. Keep the blade guard down, the anti-kickback pawls down, and the riving knife in place over the blade.

6.0 Features

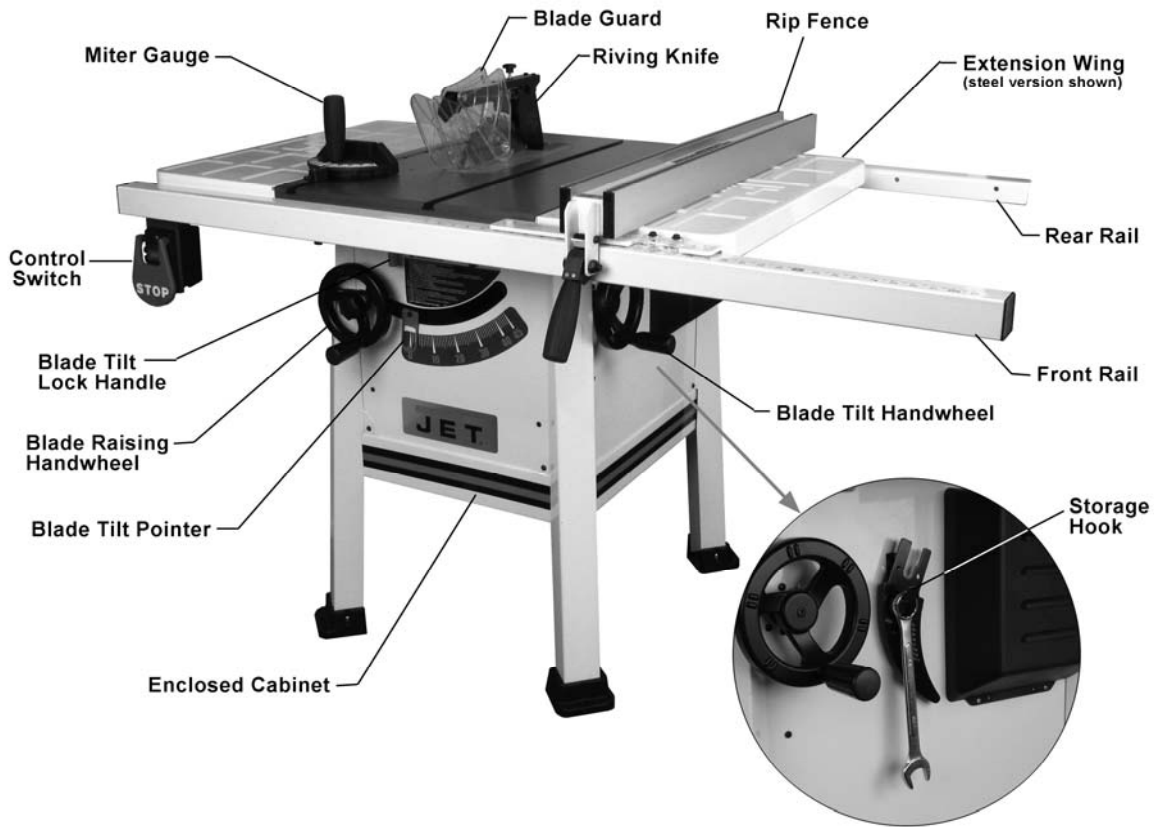

Figure 1

7.0 Specifications

Model numberJPS-10TS

<u>Stock numbers:</u>	(Steel Wings)	(Cast Iron Wings)
Saw Unit only with Steel Wings	708490
Saw Unit only with Cast Iron Wings	708491
Saw with 30" Rails/Fence Kit.....	708492K	708494K
Saw with 52" Rails/Fence Kit & Wood Ext. Table	708493K	708495K

Motor and electricals:

Motor type	totally enclosed fan cooled, induction, capacitor start, with reset button
Horsepower	1-3/4 HP
Phase.....	single
Voltage.....	115/230V (prewired 115V)
Cycle.....	60Hz
Listed FLA (full load amps).....	14/7 A
Starting amps	84 A
Running amps (no load).....	4 A
Start capacitor	200MFD, 125VAC
Run capacitor	35µF, 300VAC
Power transfer	v-belt
On/off switch	push button
Motor speed	3450 RPM
Power cord length.....	6 ft. (183cm)
Power plug installed.....	yes
Recommended circuit and fuse/breaker size ¹	20A (115V), or 15A (230V)
Sound emission.....	80 dB at 30" (762mm) from blade, without load

¹ subject to local/national electrical codes.

Arbor and blade:

Blade included.....	40 Tooth, ATB
Blade diameter.....	10" (254mm)
Arbor diameter.....	5/8" (15.88mm)
Arbor speed (RPM).....	4000
Arbor lock.....	yes
Maximum depth of cut at 90 degrees.....	3-1/8" (79mm)
Maximum depth of cut at 45 degrees.....	2-1/8" (54mm)
Maximum rip to right of blade.....	30" (52" with wood ext. table)
Maximum rip to left of blade.....	12" (305mm)
Dado maximum width.....	13/16" (20.6mm)
Dado maximum diameter.....	8" (200mm)
Blade height per one revolution of handwheel.....	3/32" (2.3mm) for 90°; 1/16" (1.7mm) for 45°
Blade tilt.....	left, 0 to 45 deg.

Materials:

Main table.....	ground cast iron
Trunnion.....	cast iron
Enclosed cabinet.....	steel
Legs.....	steel
Extension wings.....	steel or cast iron

Table:

Table dimensions.....	20"L x 27"W (508 x 686mm)
Table dimensions with wings.....	44"L x 27"W (1118 x 686mm)
Table area in front of blade at maximum height.....	10" (259mm)
Table height from floor, approximate.....	34-3/4" (883mm)
Miter slot.....	two T-slots, 3/4"W x 3/8"D (19 x 10mm)
Edge level.....	front

Dimensions:

Stand footprint.....	29"L x 26-1/2"W (737 x 673mm)
Overall dimensions of shipping carton (basic saw only).....	30"L x 29-3/4"W x 29"H (76x75.5x74.5cm)
Overall dimensions, fully assembled, accessories mounted:	
with 30" rip.....	60"L x 40"W x 41"H (1524 x 1016 x 1041mm)
with 52" rip.....	82"L x 40"W x 41"H (2083 x 1016 x 1041mm)

Dust collection:

Dust port outside diameter.....	4" (100mm)
Minimum extraction volume required.....	350 CFM (18CMM)

Weights:

	(Steel Wings)	(Cast Iron Wings)
Saw Only (Net/Shipping).....	210/223 lb (95.5/101.5 kg)	250/263 lb (113.9/119.5 kg)
Saw assembled with 30" Rail/Fence.....	252 lb (114 kg)	292 lb (132.5 kg)
Saw assembled with 52" Rail/Fence.....	302 lb (137 kg)	342 lb (155 kg)

The specifications in this manual were current at time of publication, but because of our policy of continuous improvement, JET reserves the right to change specifications at any time and without prior notice, without incurring obligations.

8.0 Setup and assembly

8.1 Shipping contents

Carton contents (see Figure 2)

NOTE: Some parts may have come pre-assembled to the table saw.

- 1 Table saw (not shown)
- 1 Blade (not shown)
- 1 Extension wing – Left (A)
- 1 Extension wing – Right (B)
- 1 Dust hood (C)
- 4 Legs (D)
- 4 Feet (E)
- 1 Miter gauge (F)
- 1 Handwheel – large mounting hole (G)
- 1 Handwheel – small mounting hole (H)
- 1 Push stick (J)
- 1 Guard assembly (K)
- 1 Riving knife (L)
- 1 Low profile riving knife (M)
- 1 Owner's manual (not shown)
- 1 Warranty card (not shown)

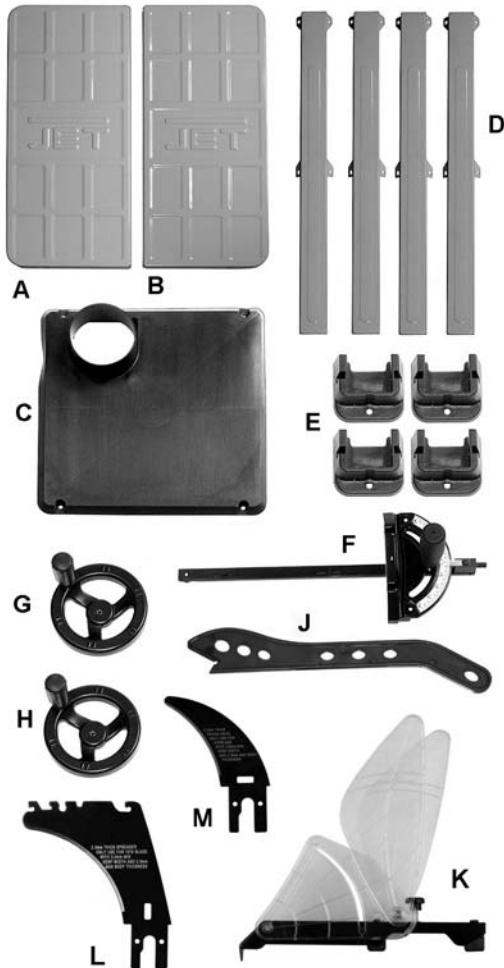

Figure 2

Hardware Package (p/n JPS10TSR-HP)

Remove contents from all packets and sort. Use Figures 3 and 4 to help identify hardware.

- 1 Lock knob (HP-1)
- 1 Bushing (HP-2)
- 4 Knobs for dust hood (HP-3)
- 8 M8x20 Hex cap screws (HP-4)
- 2 M8x10 Hex cap screws (HP-5)
- 8 M6x16 Hex cap screws (HP-6)
- 16 M6x12 Socket head button screws (HP-7)
- 10 8mm Flat washers (HP-8)
- 8 6mm Flat washers (HP-9)
- 8 6mm Hex nuts (HP-10)
- 1 M5x12 Socket head cap screw (HP-11)
- 1 5mm Lock washer (HP-12)



Figure 3

Tools included for assembly

- 1 23mm Combination wrench
- 1 10-12mm Open end wrench
- 1 11-13mm Open end wrench
- 1 4mm Hex key
- 1 2.5mm Hex key

Note: other tools not provided may be required for assembly.

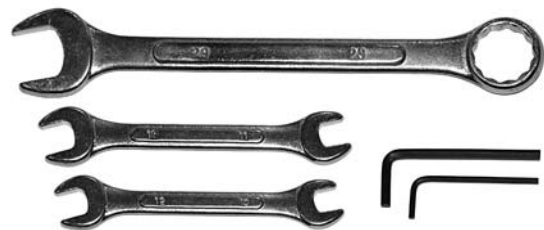

Figure 4

Note: Fence and rail assemblies, and wood extension tables and legs, are shipped in separate cartons.

⚠ WARNING Read and understand all assembly instructions before attempting assembly. Failure to comply may cause serious injury.

⚠ CAUTION The main saw unit is heavy; use of an assistant is highly recommended when moving or turning it right side up.

Tools required for assembly:

- 4mm hex key
- 10mm open-end wrench
- Rubber mallet (for wing adjustment)
- Cross point (Phillips) screwdriver

8.2 Unpacking and cleanup

1. Remove all contents from shipping carton. Keep saw table upside down (see Figure 5), and place a two-by-four or similar piece of wood under the rear of the saw – this will help when picking up the table again. Do not discard carton or packing material until saw is assembled and running satisfactorily.
2. Inspect contents for shipping damage. Report damage, if any, to your distributor.
3. Compare contents of shipping carton with the contents list in this manual. Report shortages, if any, to your distributor.

8.3 Installing legs

Referring to Figure 5:

1. Install a *foot* (C) on the bottom of each leg, using two *screws, washers and hex nuts* (HP-6/9/10) for each foot. Hand tighten only.
2. Mount four steel *legs* (A) to cabinet using sixteen *button head screws* (HP-7). Install all four screws first, then tighten with 4mm hex key.

NOTE: Remove right side motor cover for installing last leg screw. (Leave cover off until wings are installed.)

3. Turn saw right side up and allow the feet to adjust to floor surface. Tighten hex nuts with 10mm wrench.

8.4 Handwheels

Referring to Figure 6:

The JPS-10TS Table Saw is equipped with two handwheels which look identical except for the mounting holes, as follows:

1. On front of table saw, slide *bushing* (HP-2) onto *shaft* (A) followed by *handwheel* (C)

with the *larger mounting hole*, making sure to line up the flat side in the hole with the flat side on the shaft.

2. Fasten in place with *lock knob* (HP-1).
3. Slide the remaining *handwheel* (E) with the *smaller mounting hole* onto the *shaft* (F) on the right side of table saw, lining up the flat side in the hole with the flat side on the shaft.
4. Secure *handwheel* with lock washer and screw (HP-11/12), using 4mm hex key.

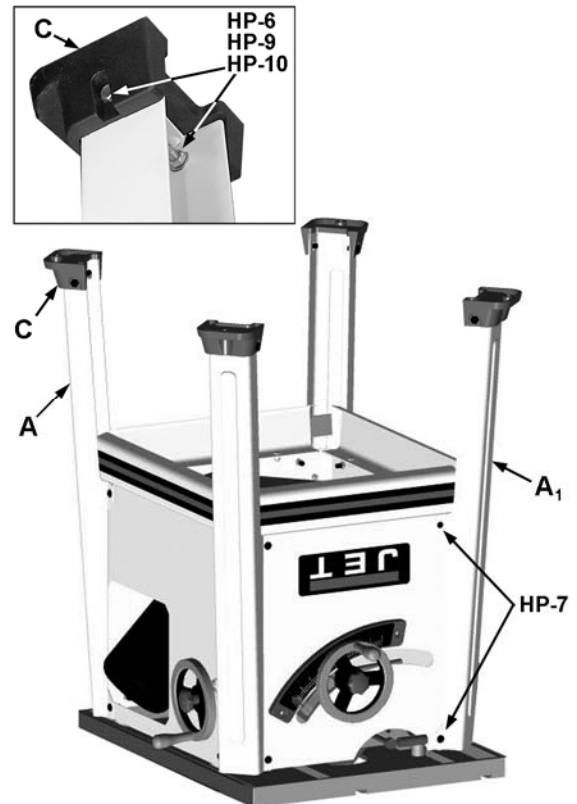

Figure 5



Figure 6

8.5 Extension wings

Referring to Figure 7:

Make sure mating surfaces are clean and free of burrs.

1. Attach right *extension wing* (J) to saw table using four *screws* and *washers* (HP-4/8). Hand-tighten only at this time.
2. Repeat for left side.

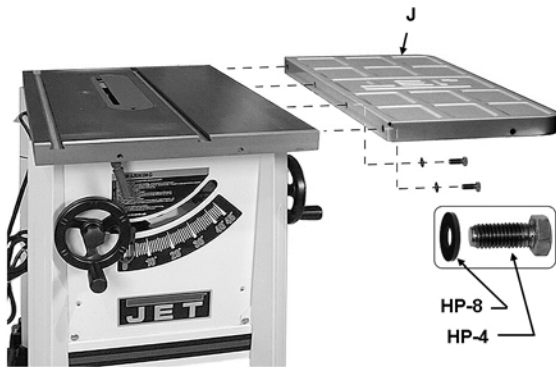

Figure 7

8.6 Extension wing adjustment

Referring to Figure 8:

Level *extension wing* (J) to saw table using a *straight edge* (L). A metal straight edge is ideal, although a carefully jointed board may also be used, as shown.

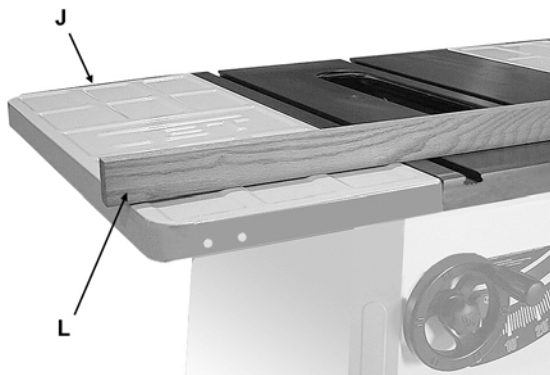

Figure 8

1. Begin with the extension wings raised slightly higher than the main table. Tighten the four screws (13mm wrench) under the *extension wing* that secure it to the saw table. Tighten these just enough to hold the wing in place but loose enough to change the wing height by tapping on it.
2. Lay *straight edge* across saw table and extension wing, extending out past edge of wing, as shown.
3. Move straight edge to several places along the wing, as you continue to nudge the

extension wing level with saw table. When extension wing is level with table, securely tighten each of the four screws.

4. Repeat steps 1 through 3 for opposite extension wing.
5. Reinstall right side motor cover.

8.7 Rails and fence

To install front and rear rails and fence, consult manual M-708482 which accompanies your fence assembly, then proceed to section 8.9.

8.8 Wood extension table

To install the optional wood table, consult manual M-708482, which accompanies your fence assembly, then proceed to section 8.9.

8.9 Switch bracket

Referring to Figure 9:

Use two screws and *washers* (HP-5/8) to secure *switch bracket* (M) to front rail.

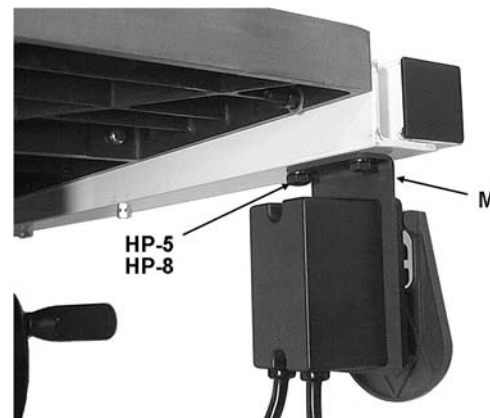

Figure 9

8.10 Dust Hood

Referring to Figure 10:

Install dust hood at rear of cabinet, using four small lock knobs (HP-3). The dust port should be toward the bottom.

A dust collection system, with minimum capacity of 350 cubic feet per minute, should be connected to the port via a 4-inch diameter hose (not included). Note: Dryer vent hose is not acceptable for this purpose.

An extensive line of JET dust collectors is available – contact your dealer or visit our website for information.

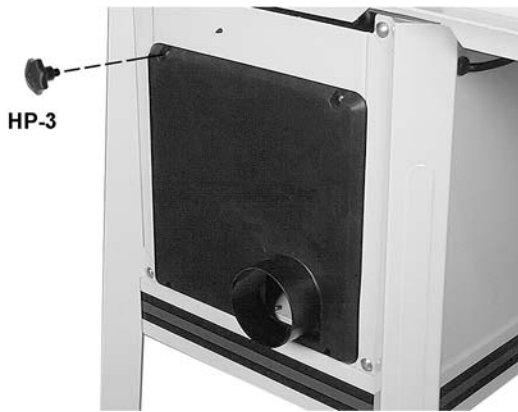

Figure 10

8.11 Riving knife

Referring to Figure 11:

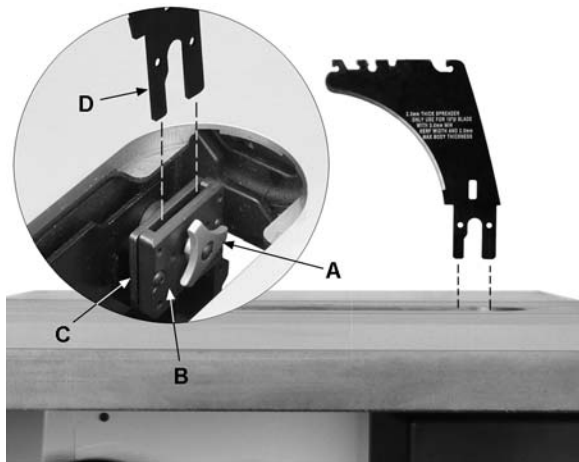

Figure 11

1. Set saw blade to 90-degree (vertical) position and raise it all the way (refer to section 10.1 – *Blade raising/tilt mechanism*).
2. Remove table insert by rotating lever (shown at E, Figure 18) and lifting up insert using finger hole.

CAUTION Use care when working around an installed blade.

3. Through the saw table opening, loosen hand knob (A, Figure 11) by rotating counter-clockwise. The *floating clamp block* (B) will move away from the *fixed block* (C), leaving a gap.
4. Slide *tabs* of riving knife (D) into slot between the two blocks, all the way down onto mounting stud.
5. Tighten the hand knob (A) to secure the riving knife.

The clamping blocks (B/C, Figure 11) are adjusted at the factory and no further adjustment of blade guard and riving knife assembly should

be necessary. However, proper alignment is very important. Before operating table saw, read section 8.15 – *Aligning Blade Guard and Riving Knife*, to verify and follow the adjustment procedure if necessary.

8.12 Anti-kickback pawls

Referring to Figures 12.

1. Push and hold the button (A) on the opposite side of the head to release the catch pin. Mount the pawl assembly straight down, in the location shown in Figure 12.
2. Pivot the head and push it downward (Figure 13) until there is an audible click. *Make sure you hear the click to verify that pawl assembly is secure!*

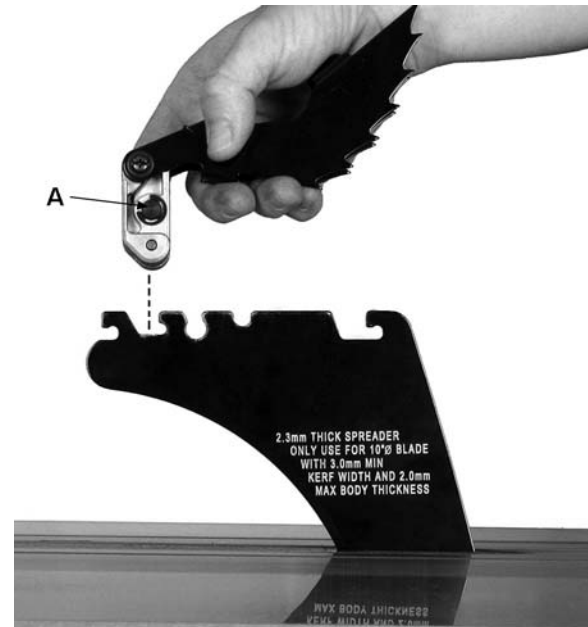

Figure 12



Figure 13

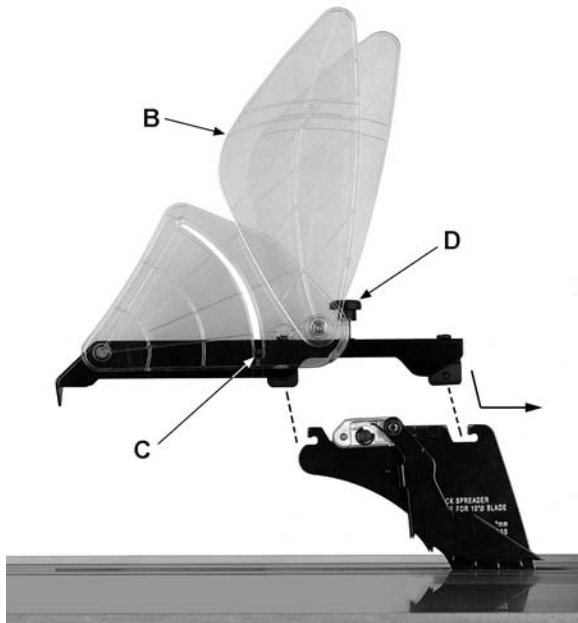

Figure 14

8.13 Blade guard

Referring to Figure 14.

1. Push up guard leaves (B) until they catch and hold on the peg (C).
2. Lower blade guard assembly onto riving knife and push it backward to seat it.
3. Tighten knob (D).
4. Pull down guard leaves into position shown in Figure 15.
5. Reverse procedure to remove guard.

IMPORTANT: Knob (D) must be tightened before operating saw with guard in place.

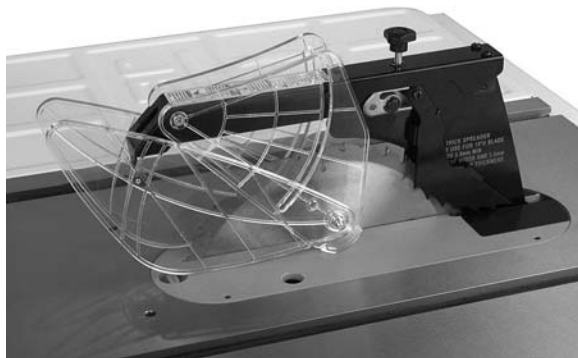

Figure 15

8.14 Blade installation/replacement

⚠WARNING When installing or changing blades, always disconnect saw from power source. Failure to comply may cause serious injury.

1. Using the handwheels, raise the blade arbor fully and lock saw at zero degrees by tightening lock knob at center of handwheel.

Referring to Figure 16:

2. Press *arbor lock button* (E) and rotate arbor until you feel arbor lock engage. Continue pressing arbor lock button.
3. Using the provided wrench, remove *arbor nut* (F) and *outer flange* (G). If replacing blade, remove old blade.
4. Place *blade* (H) on *arbor shaft* (I) making sure that the teeth point down at the front of the saw. Replace *flange* (G) and *arbor nut* (F).
5. Tighten *arbor nut* (F).

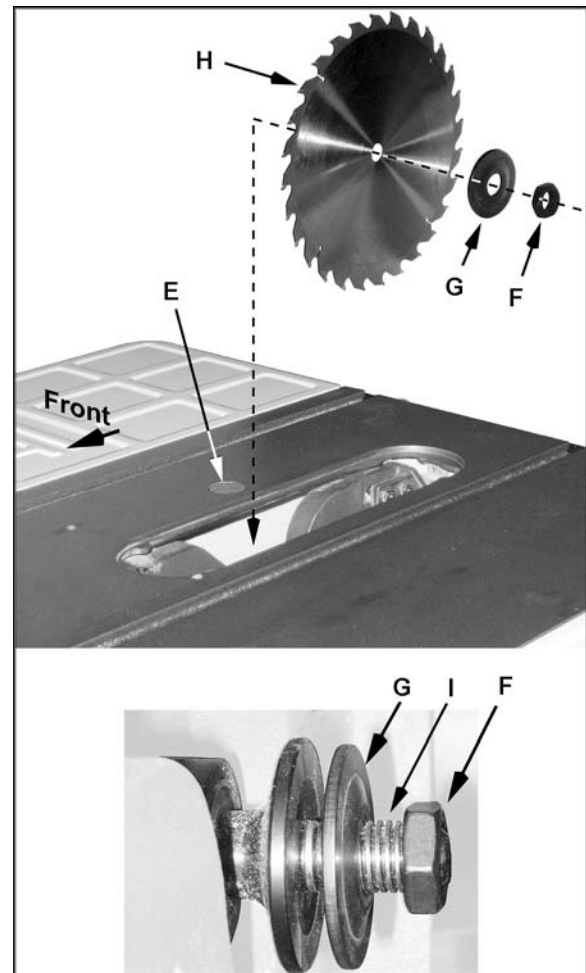

Figure 16

8.15 Aligning blade guard and riving knife

Referring to Figure 17:

1. Remove blade guard and hold anti-kickback pawls (J) away from table surface, or remove them.
2. Place an accurate straight edge (K) flush against saw blade (L) and riving knife (M). For proper alignment, blade and riving knife should be perfectly in line with the straight-edge.

If alignment is required:

3. Move straight-edge aside, and through the opening locate four set screws (N) at the corners of the clamp block. See inset, Figure 17 (riving knife removed for clarity).
4. Rotate any of the four set screws as needed, to tilt the angle of the riving knife to achieve alignment.
5. Check alignment by repeating steps 1 and 2. If necessary, repeat steps 3 and 4 until proper alignment is achieved.

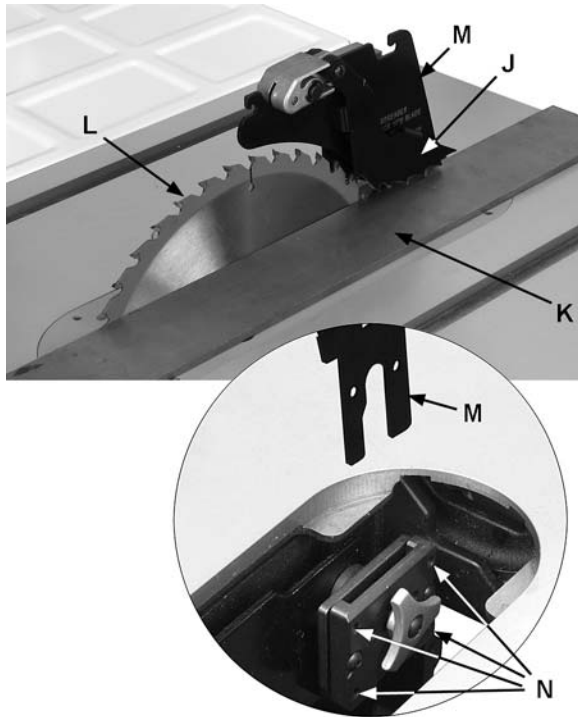

Figure 17

8.16 Low profile riving knife

A low profile riving knife is included with your saw. It mounts and adjusts in the same manner as the standard riving knife. The low profile riving knife sits just below top of blade and is used for making non-through cuts. *The blade guard is not used with this knife, so extra precautions should be taken during operation.*

8.17 Table insert

Referring to Figure 18:

1. Remove blade guard and riving knife.
2. Lower blade completely.
3. Place table insert (A) into opening with notched end (B) towards rear of table.
4. Adjust insert flush with table by turning four leveling setscrews (C) and using a straight edge (D) at different points over the insert. A 2.5mm hex key is required to adjust the setscrews.
5. Turn lever (E) so that it catches the insert and holds it against table. If the lever needs adjustment, remove insert and rotate lever up or down until it will properly catch the insert.

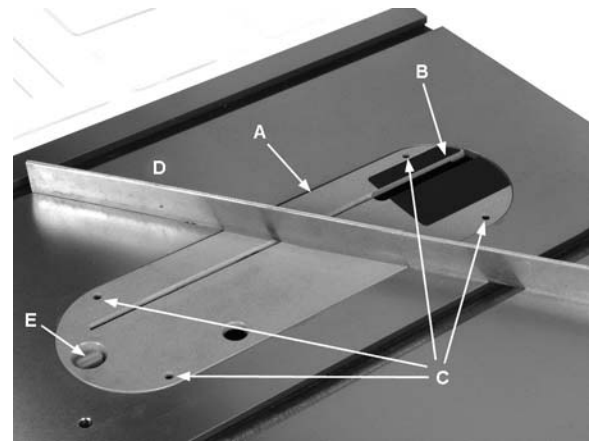

Figure 18

8.18 Miter gauge

Referring to Figure 19:

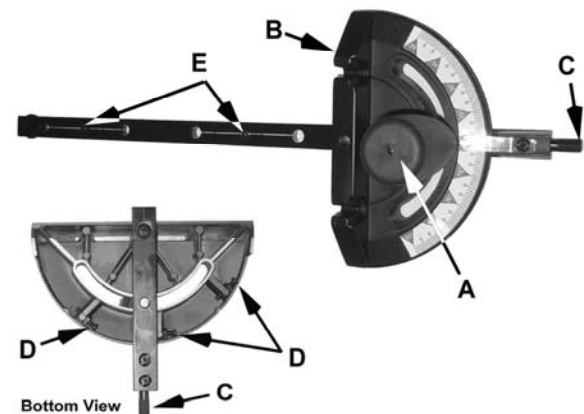

Figure 19

Operate miter gauge by loosening lock knob (A) and turning miter body (B) to desired angle.

The pin (C) functions as an index stop. When pushed in, the body will stop at -45° , 90° or $+45^\circ$ when turned, as one of three screws (D) located underneath the miter body hits the pin.

You can adjust any play of the miter gauge in the table slot by tightening set screws (E).

Calibration

If a miter angle at the -45° , 90° or $+45^\circ$ is not correct, the index stops can be adjusted by turning one of three *adjustment screws* (D), then locking the hex nut.

Note: Always make test cuts. Do not rely solely on miter gauge indicator marks.

9.0 Electrical connections

The JPS-10TS table saw is rated at 115/230V power, and is pre-wired for 115 volt. The table saw comes with a plug designed for use on a circuit with a *grounded outlet* that looks like the one pictured in **A**, Figure 20.

Before connecting to power source, be sure switch is in *off* position.

It is recommended that the table saw, when operated on **115 volt power**, be connected to a dedicated 20 amp circuit with a 20 amp circuit breaker or time-delay fuse marked "D". When operated on **230 volt power**, it is recommended that the table saw be connected to a dedicated 15 amp circuit with a 15 amp circuit breaker or time-delay fuse marked "D". **Local codes take precedence over recommendations.**

9.1 Grounding instructions

1. All Grounded, Cord-connected Tools:

In the event of a malfunction or breakdown, grounding provides a path of least resistance for electric current to reduce the risk of electric shock. This tool is equipped with an electric cord having an equipment-grounding conductor and a grounding plug. The plug must be plugged into a matching outlet that is properly installed and grounded in accordance with all local codes and ordinances.

Do not modify the plug provided - if it will not fit the outlet, have the proper outlet installed by a qualified electrician.

Improper connection of the equipment-grounding conductor can result in a risk of electric shock. The conductor with insulation having an outer surface that is green with or without yellow stripes is the equipment-grounding conductor. If repair or replacement of the electric cord or plug is necessary, do not connect the equipment-grounding conductor to a live terminal.

⚠ WARNING Check with a qualified electrician or service personnel if the grounding instructions are not completely

understood, or if in doubt as to whether the tool is properly grounded. Failure to comply may cause serious or fatal injury.

Use only 3-wire extension cords that have 3-prong grounding plugs and 3-pole receptacles that accept the tool's plug.

Repair or replace damaged or worn cord immediately.

2. Grounded, cord-connected tools intended for use on a supply circuit having a nominal rating less than 150 volts:

This tool is intended for use on a circuit that has an outlet that looks like the one illustrated in **A**, Figure 20. An adapter, shown in **B** and **C**, may be used to connect this plug to a 2-pole receptacle as shown in **B** if a properly grounded outlet is not available. The temporary adapter should be used only until a properly grounded outlet can be installed by a qualified electrician. *This adapter is not permitted in Canada.* The green-colored rigid ear, lug, and the like, extending from the adapter must be connected to a permanent ground such as a properly grounded outlet box.

3. Grounded, cord-connected tools intended for use on a supply circuit having a nominal rating between 150 - 250 volts, inclusive:

This tool is intended for use on a circuit that has an outlet that looks like the one illustrated in **D**, Figure 20. The tool has a grounding plug that looks like the plug illustrated in **D**. Make sure the tool is connected to an outlet having the same configuration as the plug. No adapter is available or should be used with this tool. If the tool must be reconnected for use on a different type of electric circuit, the reconnection should be made by qualified service personnel; and after reconnection, the tool should comply with all local codes and ordinances.

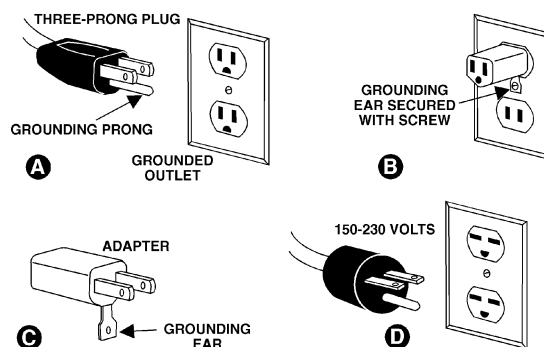

Figure 20

9.2 Voltage conversion

To switch the incoming power leads for 230 volt operation, follow the wiring diagram on the inside cover of motor junction box. To access

junction box (A, Figure 21), tilt blade to 45 degrees, and remove right side cover.

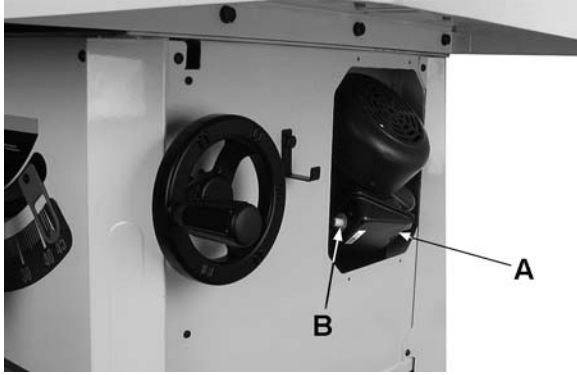

Figure 21

The plug on the end of the motor cord must be replaced with a UL/CSA listed plug rated for 240V.

9.3 Overload reset button

If saw becomes overloaded and the motor shuts off, push the re-set button on motor junction box (B, Figure 21) to restart. If overloading happens frequently, consult the Troubleshooting section in this manual.

9.4 Extension cords

USE PROPER EXTENSION CORD. Make sure your extension cord is in good condition. When using an extension cord, be sure to use one heavy enough to carry the current your product will draw. An undersized cord will cause a drop in line voltage resulting in loss of power and overheating. Table 1 shows correct size to use depending on cord length and nameplate ampere rating. If in doubt, use the next heavier gauge. The smaller the gauge number, the heavier the cord.

Ampere Rating		Volts	Total length of cord in feet			
More Than	Not More Than		25	50	100	150
		120	25	50	100	150
		240	50	100	200	300
			AWG			
0	6		18	16	16	14
6	10		18	16	14	12
10	12		16	16	14	12
12	16		14	12	Not Recommended	

Extension Cord Recommendations
Table 1

9.5 On-off switch padlock

The Table Saw is equipped with a push-button switch that will accept a safety padlock, as

shown in Figure 22. To safeguard your machine from unauthorized operation and accidental starting by young children, the use of a padlock (not included) is highly recommended. Place the key in a location that is inaccessible to children and others not qualified to use the tool.



Figure 22

10.0 Adjustments

WARNING Disconnect saw from power source before making adjustments.

10.1 Blade raising/tilt mechanism

CAUTION Never try to force the tilting mechanism past the 45° or 90° stops. This may cause the blade to go out of alignment.

Referring to Figure 23:

To raise or lower blade, loosen *lock knob* (A) and turn *handwheel* (B) on front of saw until desired height is reached. Tighten lock knob. The blade should be adjusted about 1/8" above the top surface of the material being cut.

To tilt blade, turn *lock handle* (C) counter-clockwise to loosen, turn *handwheel* (D) until desired angle is obtained, then tighten *lock handle* (C) clockwise.

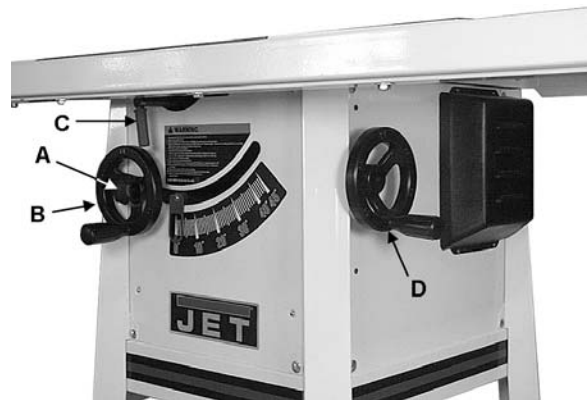

Figure 23

10.2 Adjusting 45° and 90° positive stops

1. Disconnect saw from power source.
2. Raise blade to maximum height.

3. Set blade 90° to table by turning blade tilting handwheel (D, Figure 23) counterclockwise as far as it will go. Do not force beyond stop.
4. Place a square (A, Figure 24) on the table and verify that blade (B, Figure 24) is at 90° to table. Make sure that the square is not touching a blade tooth.

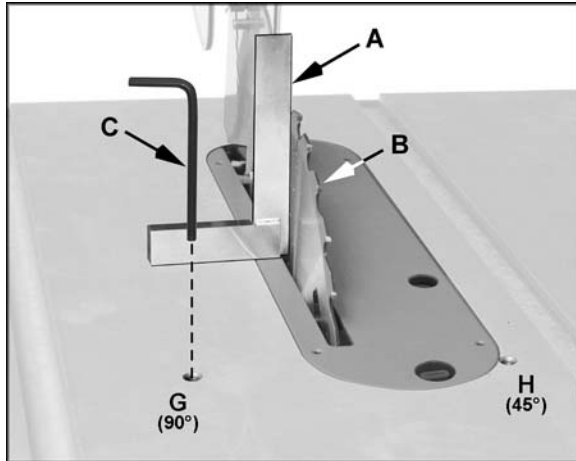

Figure 24

If adjustment is required:

5. Back out the 90° adjust setscrew (G, Figure 24) counterclockwise one or two turns with 4mm hex key (C, Figure 24).
6. Turn blade tilting handwheel until blade is exactly 90°.
7. Tighten the 90° adjust setscrew (G) until it stops, but do not force.
8. Set blade at 45° to table by turning the blade tilting handwheel clockwise (D, Figure 23) as far as it will go. Do not force beyond stop.

NOTE: If establishing a firm 90° stop is still unsuccessful, you may need to adjust the end screw (J, Figure 24a) located on the tilting leadscrew. The end screw is accessed by removing plastic cap from hole on left side of cabinet.

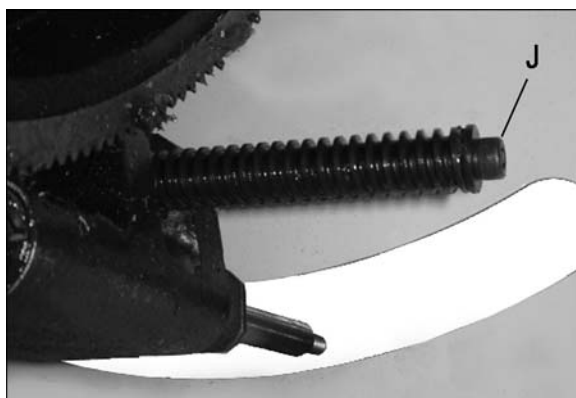

Figure 24a

9. Place a square (D, Figure 25) on the table and verify that blade (E, Figure 25) is at 45° to table. Make sure that the square is not touching a blade tooth.

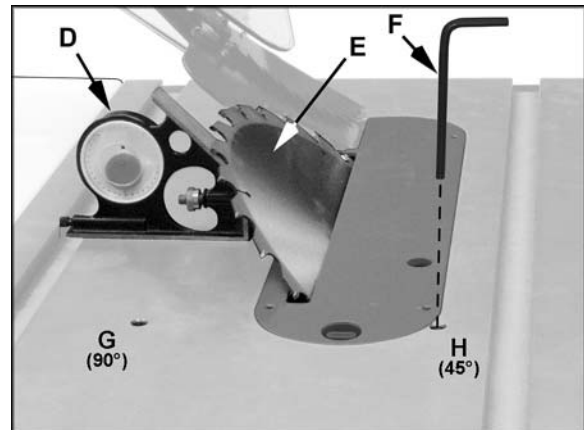

Figure 25

If adjustment is required:

10. Back out the 45° adjust setscrew (H, Figure 25) counter-clockwise one or two turns with 4mm hex key (F, Figure 20).
11. Turn blade tilt handwheel until blade is exactly 45°.
12. Tighten the 45° adjust setscrew (H) until it stops, but do not force.

NOTE: You may also need to verify the position of the stop collar (K, Figure 25a), accessed through front opening of cabinet. If adjustment is required, loosen the set screws and position the stop collar. Retighten set screws.

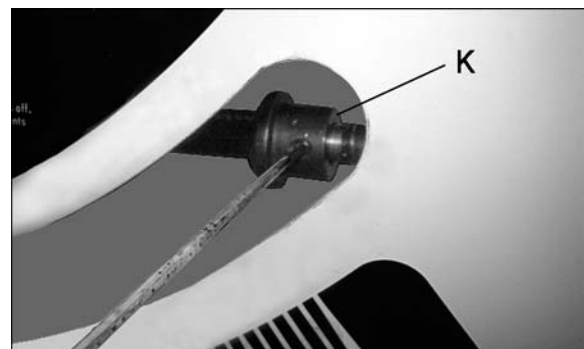

Figure 25a

Verify that blade tilt pointer (Figure 26) properly indicates 45° or 0° (90°). If not, loosen screw and adjust until pointer indicates correctly.



Figure 26

10.3 Table to blade alignment

Refer to Figures 27 and 28.

The table has been set square with blade by the manufacturer and no adjustment is necessary now. As the saw receives extensive use, however, table/blade squareness should be checked occasionally and corrected if necessary. Use the miter slot to do this:

1. Disconnect saw from power source.
2. Raise blade to maximum height.
3. Mark one tooth (A) with a grease pencil and position the tooth slightly above the top edge of table at the front.

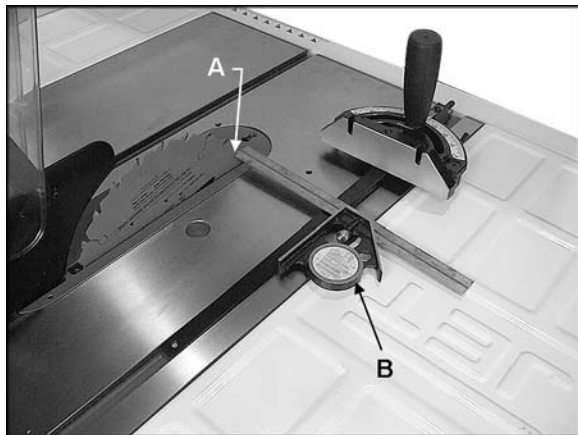

Figure 27

4. Raise the miter gauge slightly out of its slot to serve as a shoulder. Using a sliding square (B) against the side of the bar, slide the scale over until it touches the tip of the blade, and lock the scale in position. See Figure 27.
5. Rotate marked tooth (A) so that it is slightly above table top at the rear and, using the square as before, verify that the distance to the blade is the same. See Figure 28. If the distances are not the same, make a careful note of the difference.

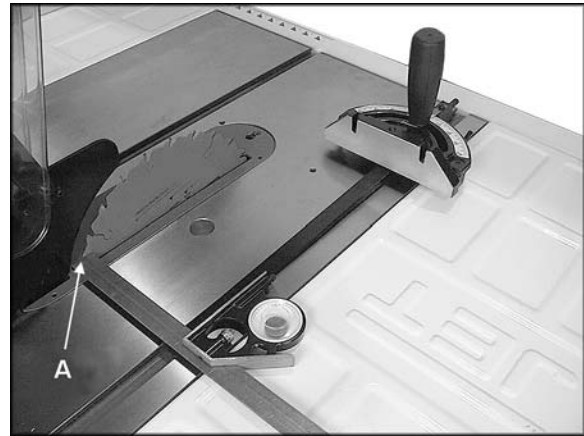

Figure 28

6. Slightly loosen the three mounting screws (#15, sect. 16.2.1) that hold the table to the cabinet; two in front, one in back.
7. Nudge table to bring miter slot in line with blade.
8. Retighten mounting screws firmly.
9. Verify the alignment, angle pointer setting, fence setting, etc. Make any further adjustments as needed.

10.4 Belt adjustment and replacement

WARNING Disconnect saw from power source before adjusting or replacing belts.

The small polyurethane belt (#2, section 16.1.1) does not require adjustment. If replacement is needed, use a flat blade screwdriver or other tool to pry the belt off the pulley while rotating pulley. Install new belt by rolling it onto pulley while rotating pulley.

To adjust tension of V-belt (Figure 29), loosen bolt in the slot of motor bracket, and shift motor as needed. Retighten bolt.

To replace V-belt (Figure 29), loosen bolt and shift motor upward to create sufficient slack in belt. Remove old belt from pulleys and install new one. Tension new belt and retighten bolt.

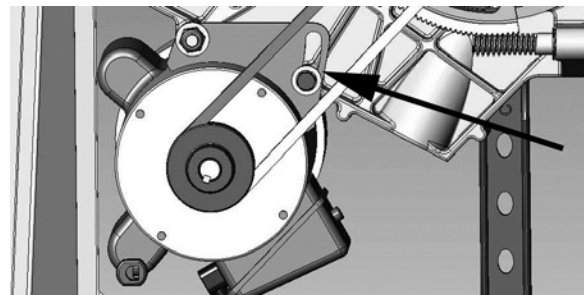

Figure 29

11.0 Operations

(NOTE: The following Figures may or may not show your saw model, but procedures are the same.)

Familiarize yourself with the location and operation of all controls and adjustments and the use of accessories such as miter gauge and rip fence.

Kickbacks

Serious injury can result from kickbacks which occur when a workpiece binds on the saw blade or binds between the blade and rip fence or other fixed object. This binding can cause workpiece to lift up and be thrown toward the operator.

Listed below are conditions which can cause kickbacks:

- ❑ Confining the cutoff piece when crosscutting or ripping.
- ❑ Releasing the workpiece before completing operation or not pushing work piece all the way past the saw blade.
- ❑ Not using the splitter/ripping knife when ripping or not maintaining alignment of the splitter/ripping knife with the saw blade.
- ❑ Using a dull saw blade.
- ❑ Not maintaining alignment of the rip fence so that it tends to angle toward rather than away from the saw blade front to back.
- ❑ Applying feed force when ripping to the cutoff (free) section of the workpiece instead of the section between saw blade and fence.
- ❑ Ripping wood that is twisted (not flat), or does not have a straight edge, or a twisted grain.

To minimize or prevent injury from kickbacks:

- ❑ Avoid conditions listed above.
- ❑ Wear a safety face shield, goggles, or glasses.
- ❑ Do not use the miter gauge and rip fence in the same operation unless provision is made by use of a facing board on the fence so as to allow the cutoff section of the workpiece to come free before the next cut is started (See Figure 38).
- ❑ As the machine receives use, the operation of the anti-kickback pawls should be checked periodically (Figure 30). If the pawls do not stop the reverse motion of a workpiece, sharpen all the points.
- ❑ Where possible, keep your face and body out of line with potential kickbacks including when starting or stopping the machine.

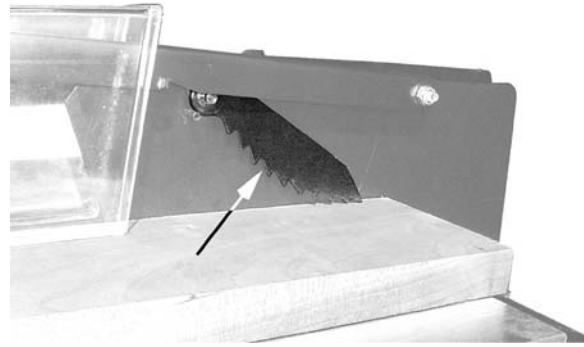

Figure 30

Dull, badly set, improper, or improperly filed cutting tools and cutting tools with gum or resin adhering to them can cause accidents. Never use a cracked saw blade. The use of a sharp, well maintained, and correct cutting tool for the operation will help avoid injuries.

Support the work properly and hold it firmly against gauge or fence. Use a push stick or push block when ripping short, narrow (6" width or less), or thin work. Use a push block or miter gauge hold-down when dadoing or molding.

For increased safety in crosscutting, use an auxiliary wood facing (Figure 31) attached to the miter gauge, using the slots or holes provided in the gauge.

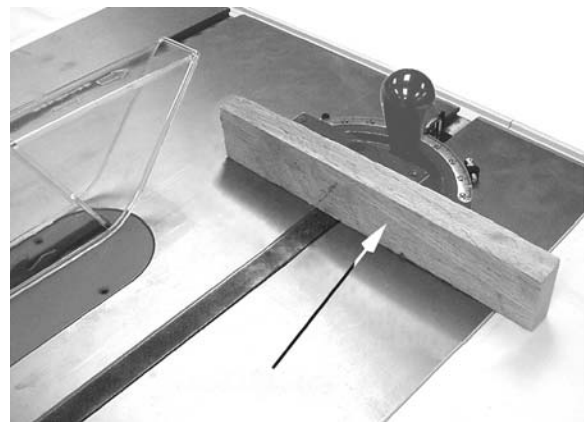

Figure 31

Never use the fence as a length stop when crosscutting. Do not hold or touch the free end or cutoff section of a workpiece. On through-sawing operations, the cutoff section must NOT be confined.

Always keep your hands out of line of the saw blade and never reach back of the cutting blade with either hand to hold the workpiece.

Bevel ripping cuts should always be made with the fence on the right side of saw blade so that the blade tilts away from the fence and minimizes the possibility of the work binding and the resulting kickback.

Rip sawing

Ripping is where the workpiece is fed with the grain into the saw blade using the fence as a guide and a positioning device to ensure the desired width of cut (Figure 32).

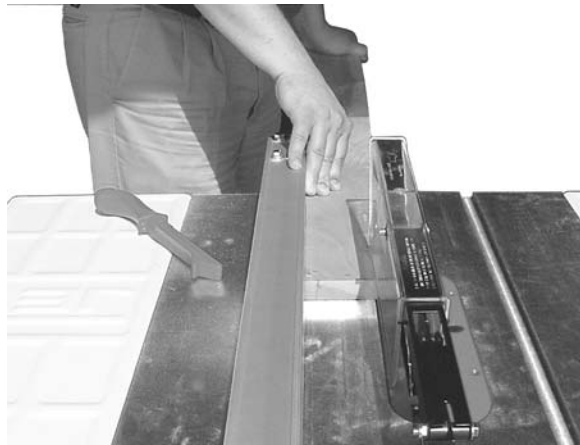

Figure 32

CAUTION Before starting a ripping cut, verify that fence is clamped securely and aligned properly.

- ❑ Never rip freehand or use miter gauge in combination with the fence.
- ❑ Never rip workpieces shorter than the saw blade diameter.
- ❑ Never reach behind the blade with either hand to hold down or remove the cutoff piece with the saw blade rotating.

Always use blade guard, splitter/riving knife and anti-kickback pawls. Make sure splitter/riving knife is properly aligned. When wood is cut along the grain, the kerf tends to close and bind on the blade and kickbacks can occur.

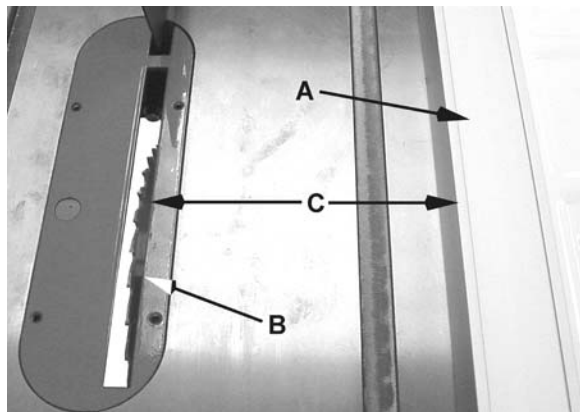

Figure 33

The rip fence (A, Fig. 33) should be set for the width of the cut (C, Fig. 33) by using the scale on the front rail, or by measuring the distance between blade (B) and fence (A). Stand out of line with saw blade and workpiece to avoid

sawdust and splinters coming off the blade or a kickback, if one should occur.

If the work piece does not have a straight edge, nail an auxiliary straight edged board on it to provide one against the fence. To cut properly, the board must make good contact with the table. If it is warped, turn the hollow side down. *Do not attempt to cut boards with significant warp.*

In ripping, use one hand to hold the board down against the fence or fixture, and the other to push it into the blade between blade and fence. If workpiece is narrower than 6" or shorter than 12", use a push stick or push block to push it through between fence and blade (Figure 34). Never push in a location such that the pushing hand is in line with the blade. Move the hand serving as a hold-down a safe distance from blade as cut nears completion. For very narrow ripping where a push stick cannot be used, use a push block or auxiliary fence. Always push the workpiece completely past the blade at the end of a cut to minimize the possibility of a kickback.



Figure 34

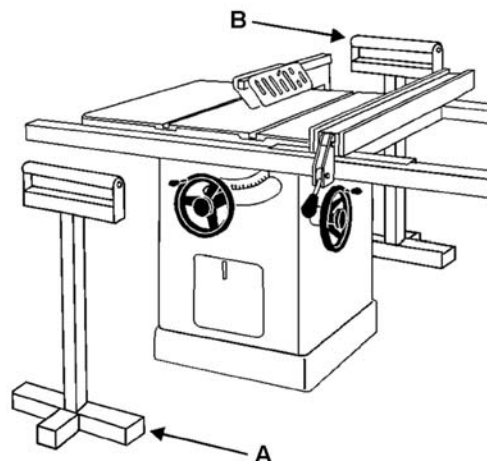

Figure 35

When ripping long boards, use a support at front of table (A, Figure 34), such as a roller stand, and a support or "tailman" (B) at the rear.

Never use the rip fence beyond the point where the carriage is flush with the end of the rails.

Have the blade extend about 1/8" above the top of the workpiece. Exposing the blade above this point can be hazardous.

Resawing

Resawing is a ripping operation in which thick boards are cut into thinner ones. Narrow boards up to 3" can be resawn in one pass. Wider boards up to 6" must be resawn in two passes.

In resawing wider boards, adjust the blade height so as to overlap the two cuts by 1/2" as shown in Figure 36. Too deep a first cut can result in binding and possible kickbacks on the second cut. Always use the same side of the board against the fence for both cuts.

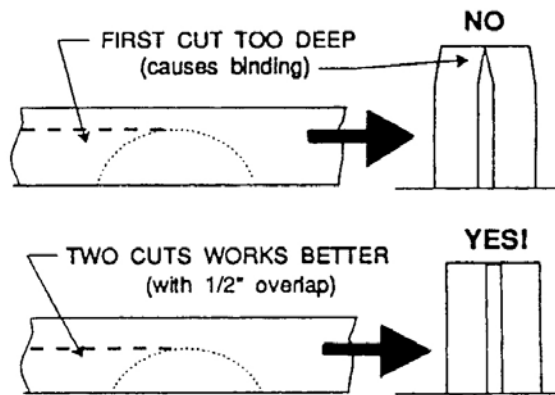

Figure 36

Crosscutting

Crosscutting is where the workpiece is fed cross grain into the saw blade using the miter gauge to support and position the workpiece (Figure 37).



Figure 37

Crosscutting should **never** be done freehand nor should the fence be used as an end stop unless an auxiliary block (A, Figure 38) is clamped to the front of the blade area such that the cutoff piece comes free of the block before cutting starts.

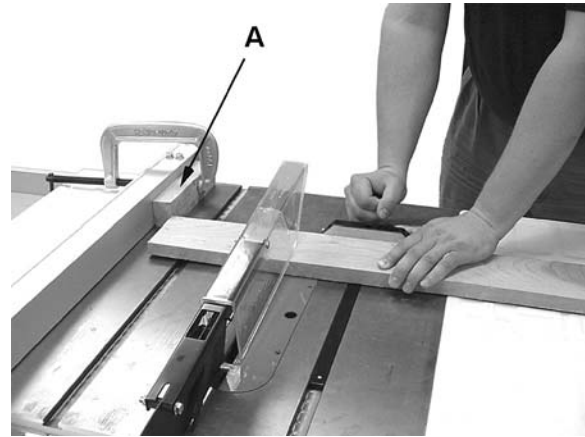

Figure 38

Length stops should not be used on the free end of the workpiece in the cutoff area.

Do **not** crosscut workpieces shorter than 6". Before starting a cut, be sure the miter gauge is securely clamped at the desired angle. Hold the workpiece firmly against the table and back against the miter gauge. **Always** use the saw guard and riving knife and make sure the riving knife is properly aligned.

For 90 degree crosscutting, most operators prefer to use the left-hand miter gauge slot. When using it in this position, hold the workpiece against the gauge with the left hand and use the right hand to advance the workpiece. When using the right hand slot for miter and compound crosscutting so that the blade tilts away from the gauge, the hand positions are reversed.

When using the miter gauge, the workpiece must be held firmly and advanced smoothly at a slow rate. If the workpiece is not held firmly, it can vibrate causing it to bind on the blade and dull the saw teeth.

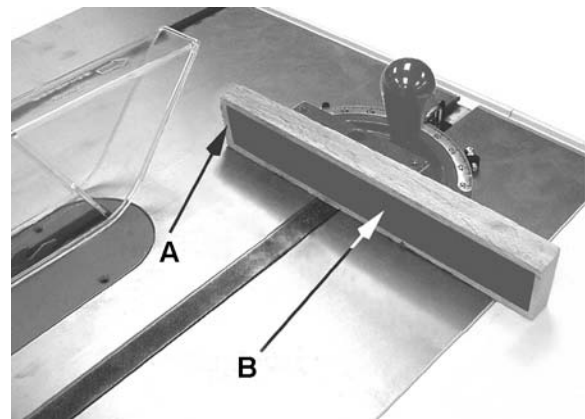

Figure 39

To improve the effectiveness of the miter gauge in crosscutting, some users mount an auxiliary wooden extension face (A, Figure 39) with a glued-on strip of sandpaper (B) to the miter gauge.

Provide auxiliary support for any workpiece extending beyond the table top with a tendency to sag and lift up off the table.

Have the blade extend about 1/8" above the top of the workpiece. Exposing the blade above this point can be hazardous.

Bevel and miter operations

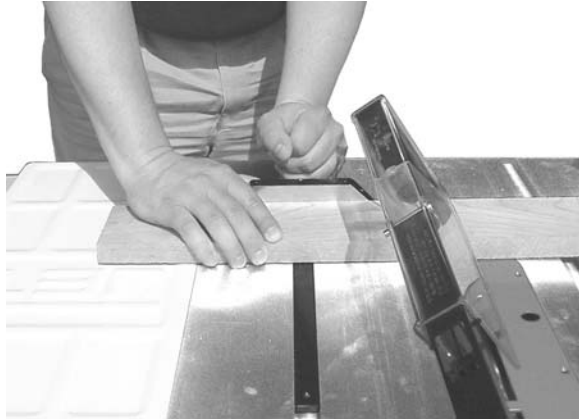

Figure 40

Bevel cut – A bevel cut is a special type of operation where the saw blade is tilted at an angle less than 90 degrees to the table top (Figure 40). Operations are performed in the same manner as ripping or crosscutting, except the fence or miter gauge should be used on the right-hand side of the blade to provide added safety in avoiding a binding action between blade and table top. When beveling with the miter gauge, the workpiece must be held firmly to prevent creeping.

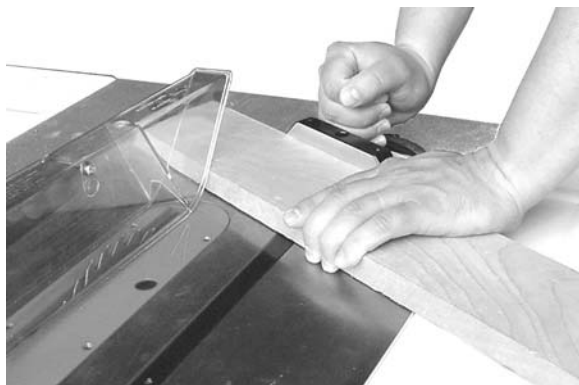

Figure 41

Mitering – Crosscuts made at an angle to the edge of the workpiece are called miters (Figure 41). Set the miter gauge at the required angle, lock the miter gauge, and make the cut the same as a normal crosscut except the

workpiece must be held extra firmly to prevent creeping.

Note: When making compound miters (with blade tilted) use the miter gauge in the **right** hand slot to provide more hand clearance and safety.

Have the blade extend only 1/8" above the top of the workpiece. Exposing the blade above this point can be hazardous.

Dado cutting – Dadoing is cutting a wide groove into a workpiece or cutting a rabbet along the edge of a workpiece. A dado insert (optional accessory, not provided) shown in Figure 42, is necessary for this type of operation.

CAUTION Do not use the standard table insert for dadoing operations.



Figure 42

The process of cutting 1/8" to 13/16" grooves in workpieces is accomplished by the use of a stacked dado blade set or an adjustable type blade mounted on the saw arbor. By using various combinations of stacked dado blades, or properly setting the dial on an adjustable blade, an accurate width dado can be made. This is very useful for shelving, making joints, tenoning, etc. The guard, riving knife, and anti-kickback pawls supplied with the saw should be used for all cutting operations where they can be used. When performing operations where the guard cannot be used, as in some dadoing operations, alternative safety precautions should be taken.

These include push sticks, feather boards, filler pieces, fixtures, jigs and any other appropriate device that can be utilized to keep operators' hands away from the blade. Upon completion of the operation requiring removal of the guard, the entire guard assembly must be placed back on the machine in its proper working order.

CAUTION Never use a dado head in a tilted position. Never operate the saw without the blade guard, riving knife and anti-kickback pawls for operations where they can be used.

12.0 Safety devices

Feather board

The feather board (Figure 43) should be made of straight grain hardwood approximately 1" thick and 4" to 8" wide depending on the size of the machine. The length is developed in accordance with intended use. Feather boards can be fastened to the table or rip fence by use of C-clamps. Alternatively, drilled and tapped holes in the table top allow the use of wing nuts and washers as a method of clamping. If this method of fastening is used, provide slots in the feather board for adjustment. (The illustration shows a method of attaching and use of the feather board as a vertical comb. The horizontal application is essentially the same except that the attachment is to the table top.)

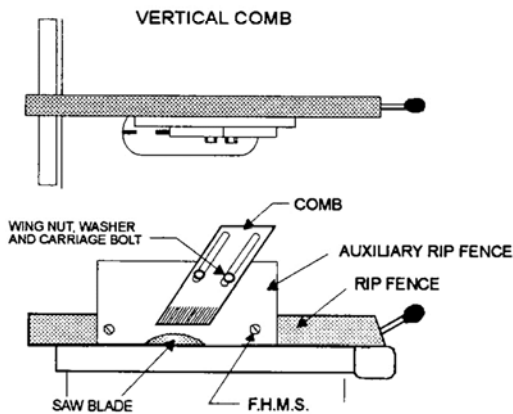
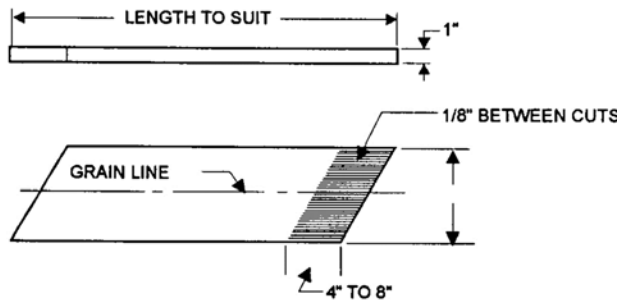

Figure 43

Filler piece

A filler piece (Figure 44) is necessary for narrow ripping and permits the blade guard to remain on the machine. It also provides space for the safe use of a push stick.

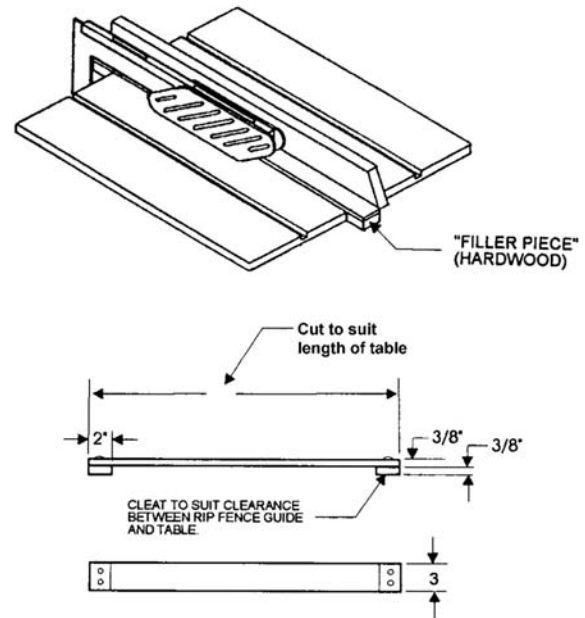

Figure 44 – Filler Piece

Push stick & push block

The use of a push block or push stick provides an added level of safety for the operator. A push stick is included with your table saw, but you may wish to make others personalized for different cutting procedures. The templates in Figures 45 and 46 offer construction details.

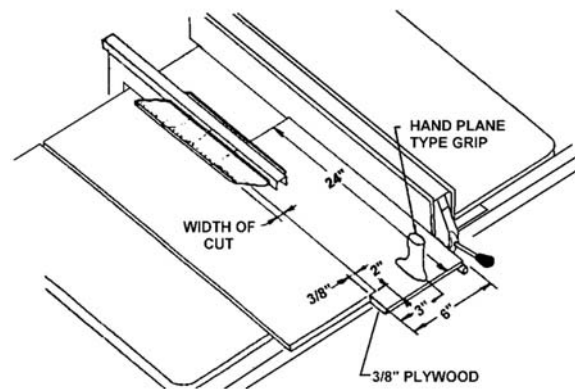

Figure 45 – Push Block Template

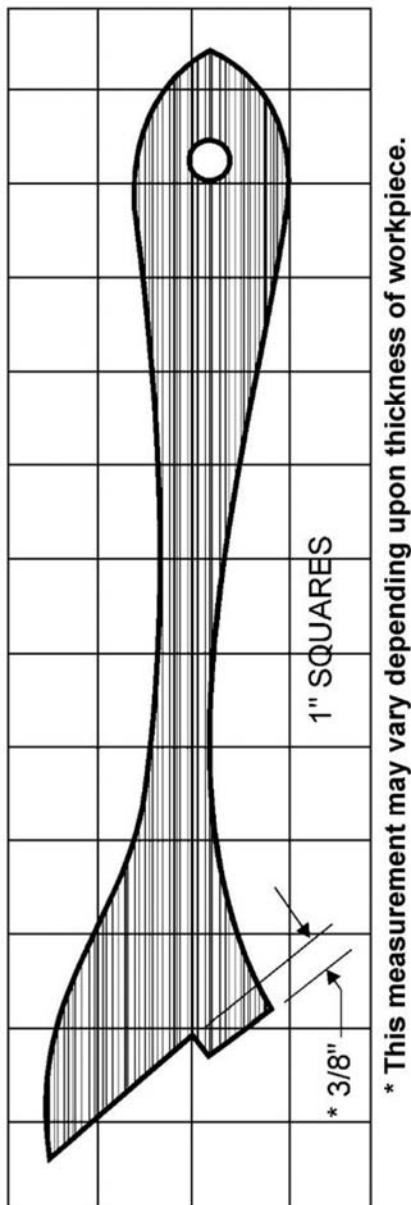

Figure 46 – Push stick template

13.0 Maintenance

⚠WARNING Always disconnect power to the machine before performing maintenance. Failure to do this may result in serious personal injury.

Cleaning

Clean the JPS-10TS according to the schedule below to ensure maximum performance.

Note—*The following maintenance schedule assumes the saw is being used every day.*

Daily:

- Wipe down the table surface and T-slots with a rust preventive.
- Clean pitch and resin from the saw blade.

Weekly:

- Clean motor housing with compressed air.
- Wipe down fence rails with a dry silicon lubricant.

Lubrication

Lubricate the areas indicated below every 12 months.

- Lubricate blade angling trunnions with 6 or 7 drops of light machine oil.
- Lubricate the blade height trunnion with 6 or 7 drops of light machine oil.
- Worm gears and threads should be lubricated with an automotive wheel bearing grease.

Check all adjustments after lubricating.

Miscellaneous

Always be aware of the condition of your machine. Routinely check the condition of the following items and repair or replace as necessary:

- Mounting bolts
- Power switch
- Saw blade
- Blade guard

14.0 Optional accessories

These accessory items, purchased separately, can enhance the functionality of your table saw. Contact your dealer to order, or call JET at the phone number on the cover.



708489 – Dado Insert for ProShop Saw with Riving Knife

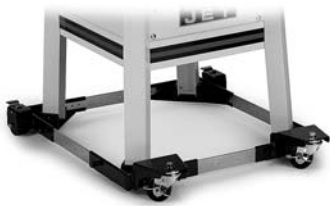

708119 – Universal Mobile Base, adjustable up to 36" x 36"



708158 – Mobile Base Extension Kit

15.0 Troubleshooting the JPS-10TS

Symptom	Possible Cause	Correction
Motor will not start	Low voltage.	Check power line for proper voltage.
	Open circuit in motor or loose connection.	Inspect all lead connections on motor for loose or open connections.
Motor will not start: fuses or circuit breakers blow.	Short circuit in line cord or plug.	Inspect cord or plug for damaged insulation and shorted wires.
	Short circuit in motor or loose connections.	Inspect all connections on motor for loose or shorted terminals or worn insulation.
	Incorrect fuses or circuit breakers in power line.	Install correct fuses or circuit breakers.
Motor overheats.	Motor overloaded.	Reduce load on motor.
	Air circulation through the motor restricted.	Clean motor fan with compressed air to restore normal air circulation.
Motor stalls, resulting in blown fuses or tripped circuit.	Motor overloaded.	Reduce load on motor.
	Short circuit in motor or loose connections.	Inspect connections on motor for loose or shorted terminals or worn insulation.
	Low voltage.	Correct the low voltage conditions.
	Incorrect fuses or circuit breakers in power line.	Install correct fuses or circuit breakers.
Machine slows when operating.	Applying too much pressure to workpiece.	Feed workpiece more slowly.
	Belt loose.	Tighten belt.
Loud, repetitive noise coming from machine.	Pulley setscrews or keys are missing or loose.	Inspect keys and setscrews. Replace or tighten if necessary.
	Motor fan is hitting the cover.	Tighten fan or shim cover.
	V-belt is defective.	Replace V-belt.
Blade not square with miter slot, or fence not square to blade.	Blade is warped.	Replace saw blade.
	Table top not parallel to blade.	Adjust table parallel to blade.
	Fence not parallel to blade.	Adjust fence parallel to blade.
Blade does not reach 90 degrees.	90 degree stop is out of adjustment.	Adjust 90 degree stop.
	Pointer bracket is hitting before the blade reaches 90 degrees.	File down the right side of the pointer bracket until the blade can reach 90 degrees.

Table 2

16.0 Replacement Parts

Replacement parts are listed on the following pages. To order parts or reach our service department, call 1-800-274-6848 Monday through Friday (see our website for business hours, www.jettools.com). Having the Model Number and Serial Number of your machine available when you call will allow us to serve you quickly and accurately.

16.1.1 Motor and Trunnion – Exploded View

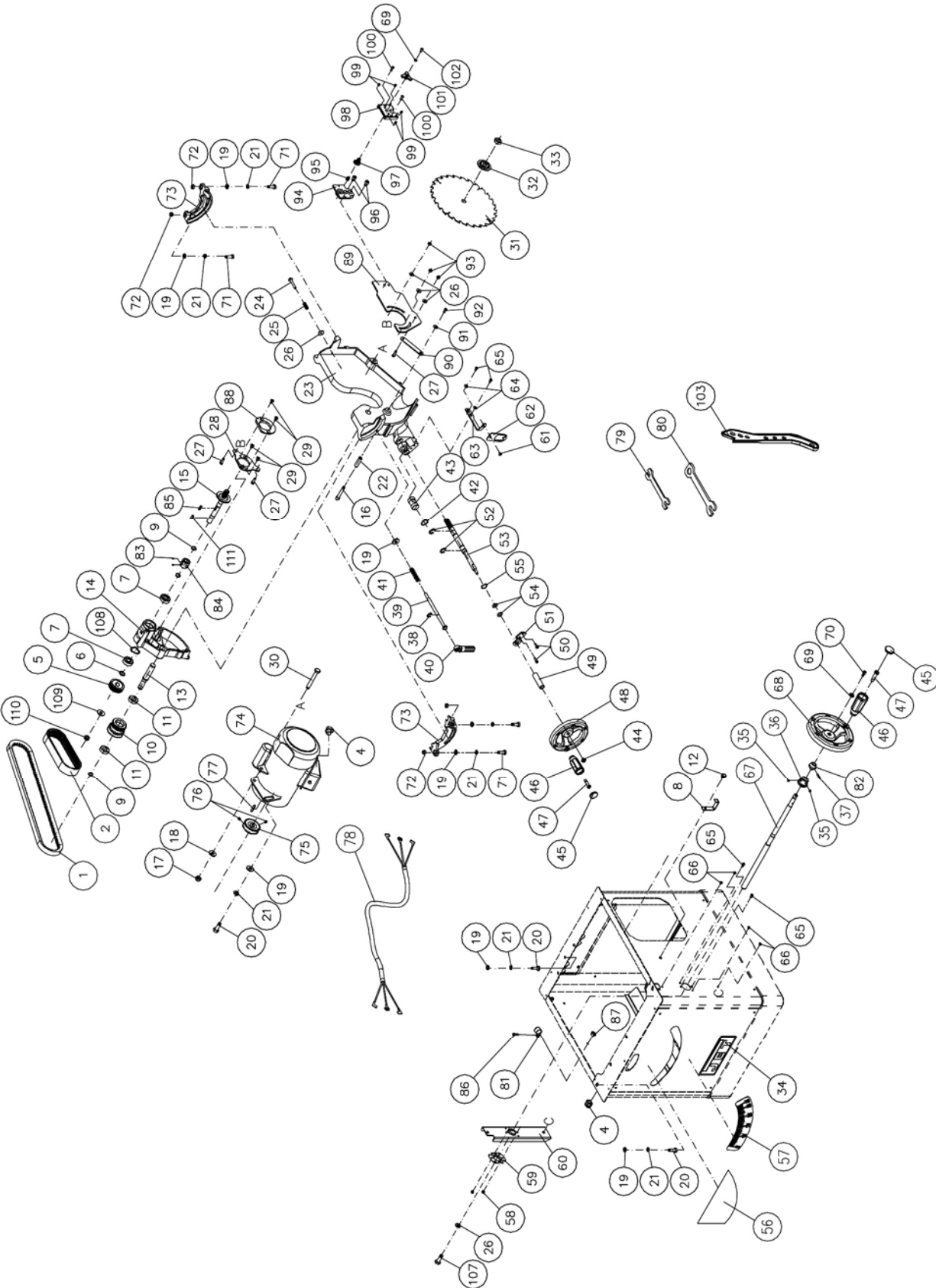

16.1.2 Motor and Trunnion – Parts List

Index No	Part No	Description	Size	Qty
1	VB-A31	V-Belt	A-31	1
2	JPS10TSR-102	Belt	125J-6	1
4	JPS10TS-351	Strain Relief	SB8R-3	2
5	JPS10TSR-105A	Pulley (s/n 14053173 and higher)		1
6	JPS10TSR-106	Washer		1
7	BB-6202VV	Ball Bearing	6202-2NSE	2
8	JPS10TSR-108	Hook		1
9	JWTS10-109	Retaining Ring, External	STW-15	3
10	JPS10TSR-110	Pulley		1
11	BB-6002VV	Ball Bearing	6002-2NSE	2
12	TS-1490011	Hex Cap Screw	M8-1.25Px12	1
13	JPS10TSR-113	Shaft		1
14	JPS10TSR-114A	Bearing Arm (s/n 14053173 and higher)		1
15	JPS10TSR-115A	Arbor (s/n 14053173 and higher)		1
16	TS-1504101	Socket Head Cap Screw	M8-1.25Px50	1
17	TS-1541041	Nylon Lock Hex Nut	M10	1
18	TS-1550071	Flat Washer	M10	1
19	TS-1550061	Flat Washer	M8	9
20	TS-1504041	Hex Cap Screw	M8-1.25Px20	4
21	TS-2361081	Lock Washer	M8	8
22	JPS10TSR-122	Bushing		1
23	JPS10TSR-123	Center Trunnion		1
24	JWTS10-124	Hex Flange Bolt	M6x40	1
25	JWTS10-125	Spring		1
26	TS-1550041	Flat Washer	M6	6
27	TS-1482041	Hex Cap Screw	M6-1.0Px20	3
28	JPS10TSR-128	Fixing Plate		1
29	TS-2286121	Phillips Flat Head Machine Screw	M6-1.0Px12	4
30	TS-2210801	Hex Cap Screw	M10x80	1
31	JPS10TSR-131	Blade	10"x5/8"x40T	1
32	JWTS10-132	Flange		1
33	JWTS10-133	Arbor Nut	5/8"-12	1
34	JETLOGO-1	JET Logo Plate		1
35	TS-1523011	Socket Set Screw	M6x6	2
36	JPS10TS-136	Fixing Ring		1
37	JPS10TS-137	Spring Pin	Ø4x18	1
38	JWTS10-138	E-Clip	ETW-8	1
39	JPS10TSR-139	Bolt		1
40	JWTS10-140	Handle		1
41	JWTS10-141	Spring		1
42	JPS10TSR-141	Retaining Ring	RTW-24	1
43	JWTS10-143	Guide Shaft		1
44	JPS10-144	Knob		1
	JPS10TS-FHA	Front Hand Wheel Assembly (#45 thru #48)		1
45	JWTS10-145	Handle Cap		2
46	JWTS10-146	Handle		2
47	JWTS10-147	Shaft		2
48	JPS10TS-148	Hand Wheel		1
49	JPS10TSR-149	Bushing		1
50	TS-1502031	Socket Head Cap Screw	M5x12	3
51	JWTS10-151	Plate		1
52	JWTS10-152	E-Clip	ETW-12	2
53	JPS10TSR-153	Shaft		1
54	JWTS10-154	O-Ring	P12	2

Index No	Part No	Description	Size	Qty
55	JWTS10-155	Wave Washer	WW-16	1
56	LM000636	Warning Label		1
57	JPS10TSR-157	Angle Scale		1
58	TS-1541011	Nylon Lock Hex Nut	M5	2
59	JWTS10-159	Collar		1
60	JPS10TSR-160	Support Bracket		1
61	TS-2284082	Phillips Pan Head Machine Screw	M4x8	1
62	JPS10TS-162	Pointer		1
63	JPS10TSR-163	Bracket		1
64	TS-1550031	Flat Washer	M5	2
65	TS-1533042	Phillips Pan Head Machine Screw	M5x12	4
66	990805	Self Tapping Screw	M4x10	4
67	JPS10TS-167	Shaft		1
	JPS10TS-SHA	Side Hand Wheel Assembly (#68, #45 thru #47)		1
68	JPS10TS-168	Hand Wheel		1
69	TS-1551031	Lock Washer	M5	2
70	TS-1502031	Socket Head Cap Screw	M5x12	2
71	TS-1490041	Hex Cap Screw	M8x25	4
72	TS-1540061	Hex Nut	M8	4
73	JPS10TSR-173	Front & Rear Trunnion		2
74	JPS10TSR-174	Motor	1-3/4HP, 1Ph, 115/230V	1
	JPS10TSR-174MF	Motor Fan (not shown)		1
	JPS10TSR-174MFC	Motor Fan Cover (not shown)		1
	JPS10TSR-174CS	Centrifugal Switch (not shown)		1
	JPS10TSR-174SCC	Starting Capacitor Cover (not shown)		1
	JPS10TSR-174RCC	Running Capacitor Cover (not shown)		1
	JPS10TSR-174SC	Starting Capacitor (not shown)	200MFD, 125VAC	1
	JPS10TSR-174RC	Running Capacitor (not shown)	35 μ F, 300VAC	1
	JPS10TSR-174JB	Junction Box (not shown)		1
	JPS10TSR-174JBC	Junction Box Cover (not shown)		1
	JPS10TS-174OL	Overload		1
	JPS10TSR-174DC	Dust Cover		1
75	JPS10TSR-175	Pulley		1
76	TS-1523041	Socket Set Screw	M6x12	2
77	JPS10TSR-177	Key	5x5x22	1
78	JPS10TSR-178	Motor Wire		1
79	JBOS5-106	Open end Wrench	#10 - #12	1
80	JPS10TSR-180	Blade Open End Wrench	#23	1
81	JPS10TS-181	Motor Cord Clamp		2
82	JPS10TS-182	Turning Ball		1
83	TS-1521011	Socket Set Screw	M4x4	2
84	JPS10TS-184	Stop Collar		1
85	JPS10TS-185	Key	5x5x18	1
86	TS-1532042	Phillips Pan Head Machine Screw	M4x12	2
87	TS-1540021	Hex Nut	M4	3
88	JPS10TSR-188	Plate		1
89	JPS10TSR-189	Extension Plate		1
90	JPS10TSR-190	Bar		1
91	JPS10TSR-191	Washer		1
92	TS-1481031	Hex Cap Screw	M5-0.8x12	1
93	TS-1541021	Nylon Lock Hex Nut	M6-1.0P	3
94	JPS10TSR-194	Riving Knife Clamp Base		1
95	JPS10TSR-195	Spring		1
96	TS-1504021	Socket Head Cap Screw	M8-1.25Px12	2
97	JPS10TSR-197	Bolt		1
98	JPS10TSR-198	Riving Knife Clamp Plate		1
99	JPS10TSR-199	Nylon Set Screw	M6-1.0Px8	4
100	TS-1533052	Phillips Pan Head Machine Screw	M5-0.8Px16	2
101	JPS10TSR-101	Lock Knob		1

Index No	Part No	Description	Size	Qty
102	TS-2245122	Socket Head Button Screw	M5-0.8Px12	1
103	JPS10TSR-103	Push Block		1
104	JPS10TSR-104	Open End Wrench (not shown)	#11 - #13	1
105	JPS10TSR-105	Angle Wrench (not shown)	2.5mm	1
106	TS-152705	Angle Wrench (not shown)	4mm	1
107	JPS10TSR-107	Nylon Socket Head Cap Screw	M6x15	1
108	JPS10TSR-1108	Wave Washer (s/n 14053173 and higher)		1
109	JPS10TSR-109	Washer (s/n 14053173 and higher)		1
110	TS-2342101	Nylon Nut (s/n 14053173 and higher)	M10-1.5P	1
111	JPS10TSR-111	Key (s/n 14053173 and higher)	5x5x10	1
	STRIPE-1-3/4	JET Stripe (not shown)	1-3/4" w	per ft.
	JPS10TSR-HP	Hardware Package (see section 8.1 for included items)		1

16.2.1 Table and Cabinet – Exploded View

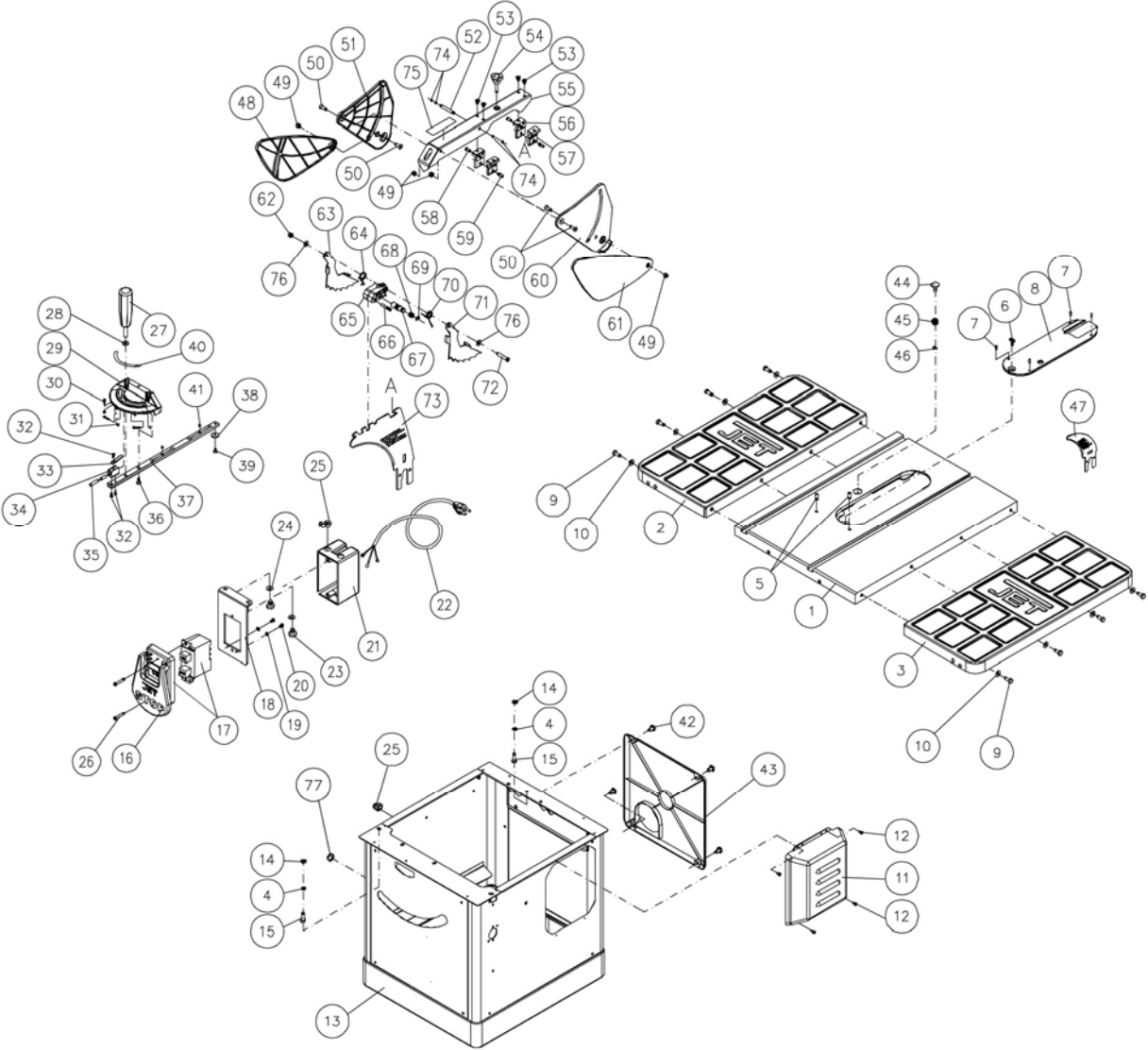

16.2.2 Table and Cabinet – Parts List

Index No	Part No	Description	Size	Qty
1	JPS10TSR-301	Table		1
2	JPS10TS-302	Left Steel Extension Wing		1
3	JPS10TS-303	Right Steel Extension Wing		1
4	TS-2361081	Lock Washer	M8	3
5	TS-1524051	Socket Set Screw	M8x20	2
	JPS10TSR-TIA	Table Insert Assembly (#6 thru #8)		1
6	JPS10TSR-306	Lock Knob		1
7	TS-1522041	Socket Set Screw	M5-0.8Px12	4
8	JPS10TSR-308	Table Insert		1
9	TS-1490031	Hex Cap Screw	M8x20	8
10	TS-1550061	Flat Washer	M8	8
11	JPS10TS-311	Cover		1
12	TS-1532032	Phillips Pan Head Machine Screw	M4x10	4
13	JPS10TSR-313	Cabinet		1
14	TS-1550061	Flat Washer	M8	3
15	TS-1490031	Hex Cap Screw	M8x20	3
16	JPS10TS-342	STOP Switch Paddle		1
17	JPS10TS-343	Main Switch w/ Face Plate		1
18	JPS10TS-344	Switch Plate		1
19	JPS10TS-345	External Tooth Lock Washer	M4	2
20	TS-2171012	Phillips Pan Head Machine Screw	M4x6	2
21	JPS10TS-347	Switch Box		1
22	JPS10TS-348	Power Cord		1
23	TS-1490011	Hex Cap Screw	M8x10	2
24	TS-1550061	Flat Washer	M8	2
25	JPS10TS-351	Strain Relief	SBRS-3	3
26	TS-2284302	Phillips Pan Head Machine Screw	M4x30	2
	JPS10TS-MG	Miter Gauge Assembly (#27 thru #41)		1
27	JPS10TS-327	Handle		1
28	TS-0680041	Flat Washer	3/8"	1
29	JWTS10-329	Miter Gauge Body		1
30	TS-2284202	Phillips Pan Head Machine Screw	M4x20	3
31	TS-1540021	Hex Nut	M4	3
32	TS-1533032	Phillips Pan Head Machine Screw	M5x10	3
33	JWTS10-333	Pointer		1
34	JWTS10-334	Bracket		1
35	JWTS10-335	Stop Pin		1
36	JWTS10-336	Screw		1
37	JPS10TS-337	Miter Bar		1
38	JWTS10-338	Guide Washer		1
39	JWTS10-339	Flat Head Screw	M6x8	1
40	JPS10TS-340	Scale		1
41	TS-0270011	Socket Set Screw	5/16"-18x1/4"	2
42	JPS10TS-357	Lock Knob		4
43	JPS10TS-358	Dust Chute Cover		1
44	JPS10TSR-344	Lock Plunger		1
45	JPS10TS-360	Spring		1
46	JPS10TS-361	E-Clip	ETW-7	1
47	JPS10TSR-347	Low Profile Riving Knife		1
	JPS10TSR-BGA	Blade Guard Assembly (#48 thru #76)		1
	JPS10TSR-UGA	Upper Guard Assembly (#48 thru #61,74,75)		1
48	JPS10TSR-348	Left Side outer Blade Guard		1
49	TS-1541011	Nylon Lock Hex Nut	M5	4
50	JPS10TSR-350	Flat Head Screw	M5-0.8Px15	4
51	JPS10TSR-351	Left Side Inner Blade Guard		1
52	JPS10TSR-352	Shaft		1
53	JPS10TSR-353	Pan Head Screw	M5-0.8Px6	4

Index No	Part No	Description	Size	Qty
54	JPS10TSR-354	Lock Knob		1
55	JPS10TSR-355	Support Arm		1
56	JPS10TSR-356	Left Fixing Bracket		2
57	JPS10TSR-357	Right Fixing Bracket		2
58	TS-1532032	Phillips Pan Head Machine Screw	M4-0.7Px10	2
59	JPS10TSR-359	Lock Pin		2
60	JPS10TSR-360	Right Side Inner Blade Guard		1
61	JPS10TSR-361	Right Side Outer Blade Guard		1
	JPS10TSR-AKPA	Anti-Kickback Pawl Assembly (#62 thru #72,76)		1
62	TS-1541011	Nylon Lock Hex Nut	M5-0.8P	1
63	JPS10TSR-363	Left Side Anti-kickback Pawl		1
64	JPS10TSR-364	Left Side Spring		1
65	JPS10TSR-365	Anti-Kickback Pawl Bracket		1
66	JPS10TSR-366	Lock Pin		1
67	JPS10TSR-367	Lock Shaft		1
68	JPS10TSR-368	Spring		1
69	JPS10TS-361	E-Clip	ETW-7	1
70	JPS10TSR-370	Right Side Spring		1
71	JPS10TSR-371	Right Side Anti-kickback Pawl		1
72	TS-2285302	Phillips Pan Head Machine Screw	M5-0.8Px30	1
73	JPS10TSR-373	Riving Knife		1
74	JPS10TSR-374	O-Ring	P3	4
75	JPS10TSR-375	Warning Label		1
76	TS-1550031	Flat Washer	M5	2
77	JPS10TSR-377	Cap		1

16.3.1 Stand Assembly – Exploded View

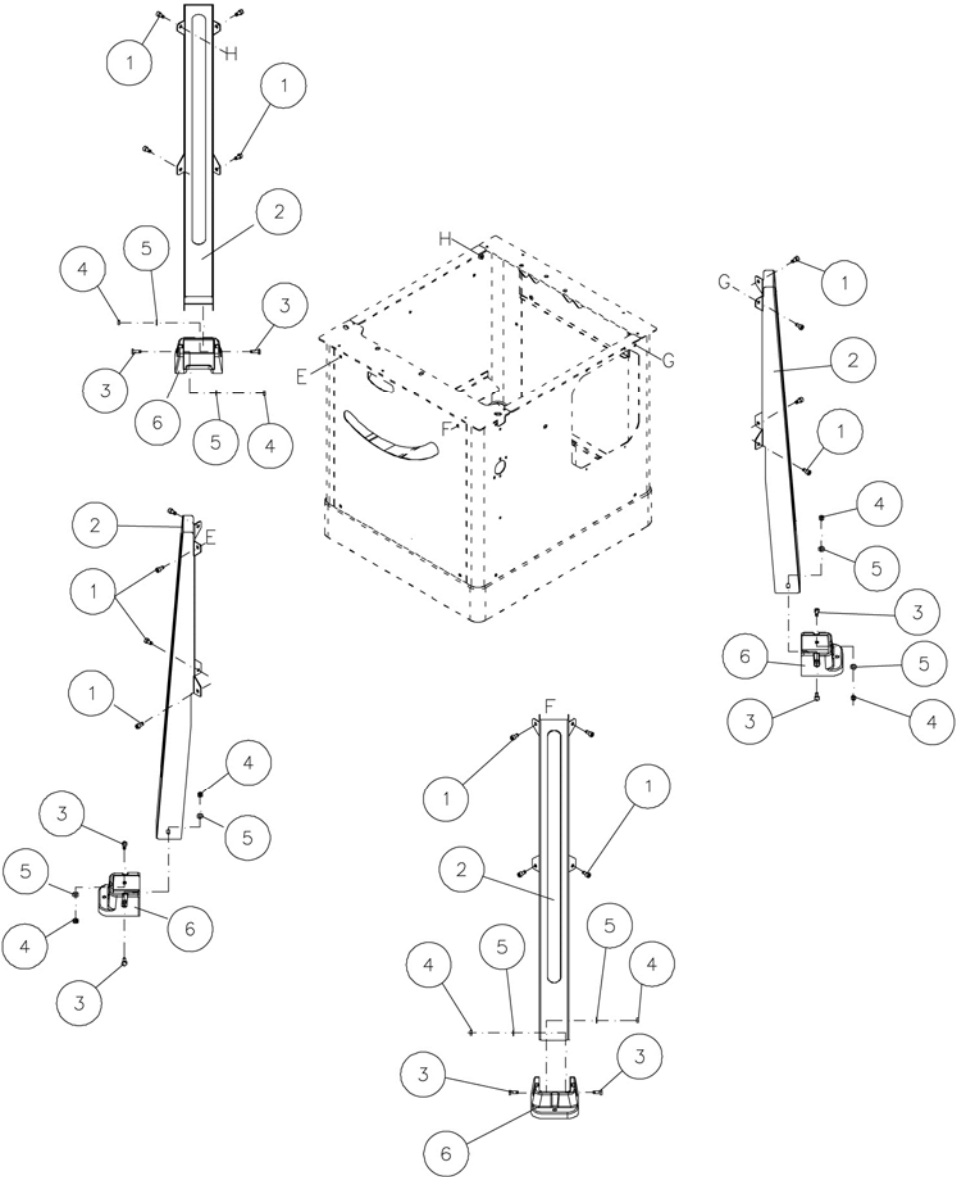

16.3.2 Stand Assembly – Parts List

Index No	Part No	Description	Size	Qty
1.....	TS-2246122.....	Socket Head Button Screw.....	M6x12.....	16
2.....	JPS10TSR-402.....	Leg.....		4
3.....	TS-1482031.....	Hex Cap Screw.....	M6x16.....	8
4.....	TS-2311061.....	Hex Nut.....	M6.....	8
5.....	TS-1550041.....	Flat Washer.....	M6.....	8
6.....	JPS10TS-406.....	Foot.....		4
.....	JPS10TS-SHP.....	Stand Hardware Package (#1,3,4,5).....		

16.4.1 Cast Iron Wings – Exploded View

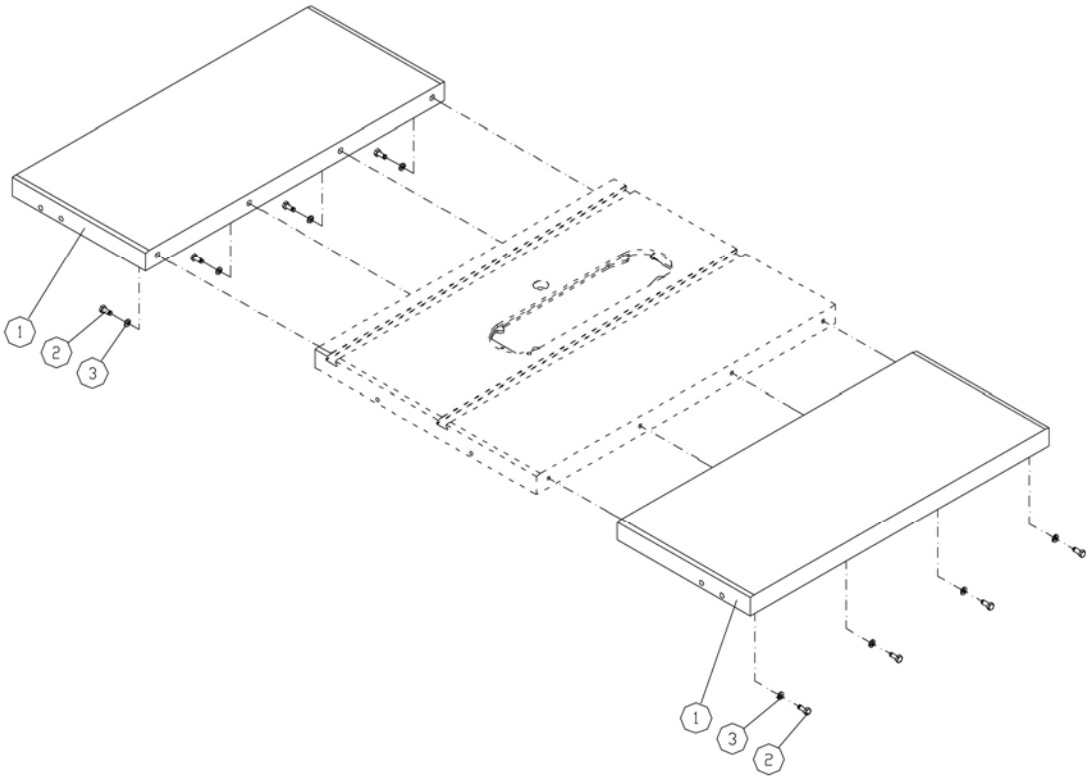

16.4.2 Cast Iron Wings – Parts List

Index No.	Part No.	Description	Size	Qty
1	JPS10TS-501	Cast Iron Wing		2
2	TS-1490031	Hex Cap Screw	M8x20	8
3	TS-1550061	Flat Washer	M8	8

17.1 Electrical Connections – 115V

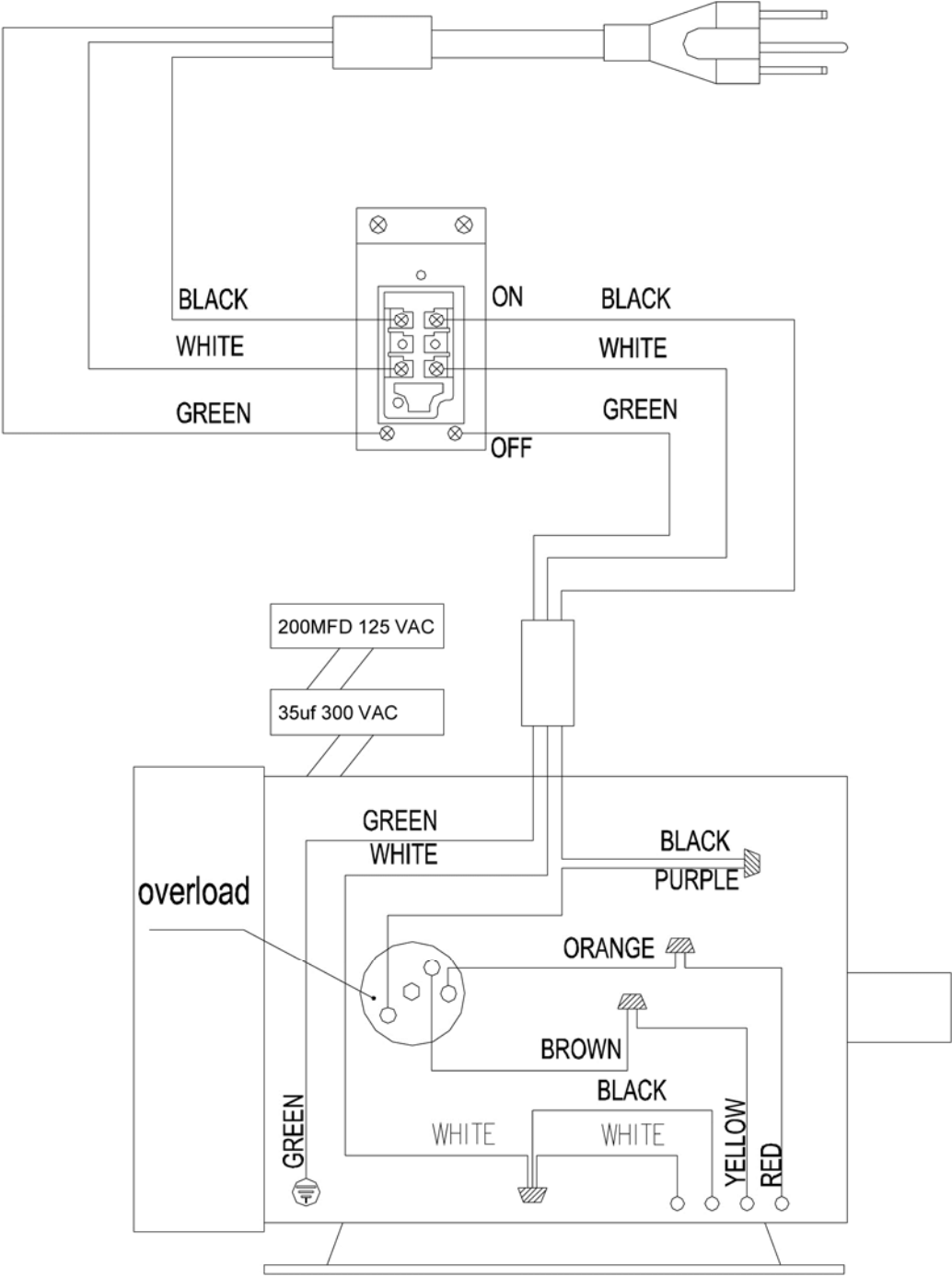

17.2 Electrical Connections – 230V

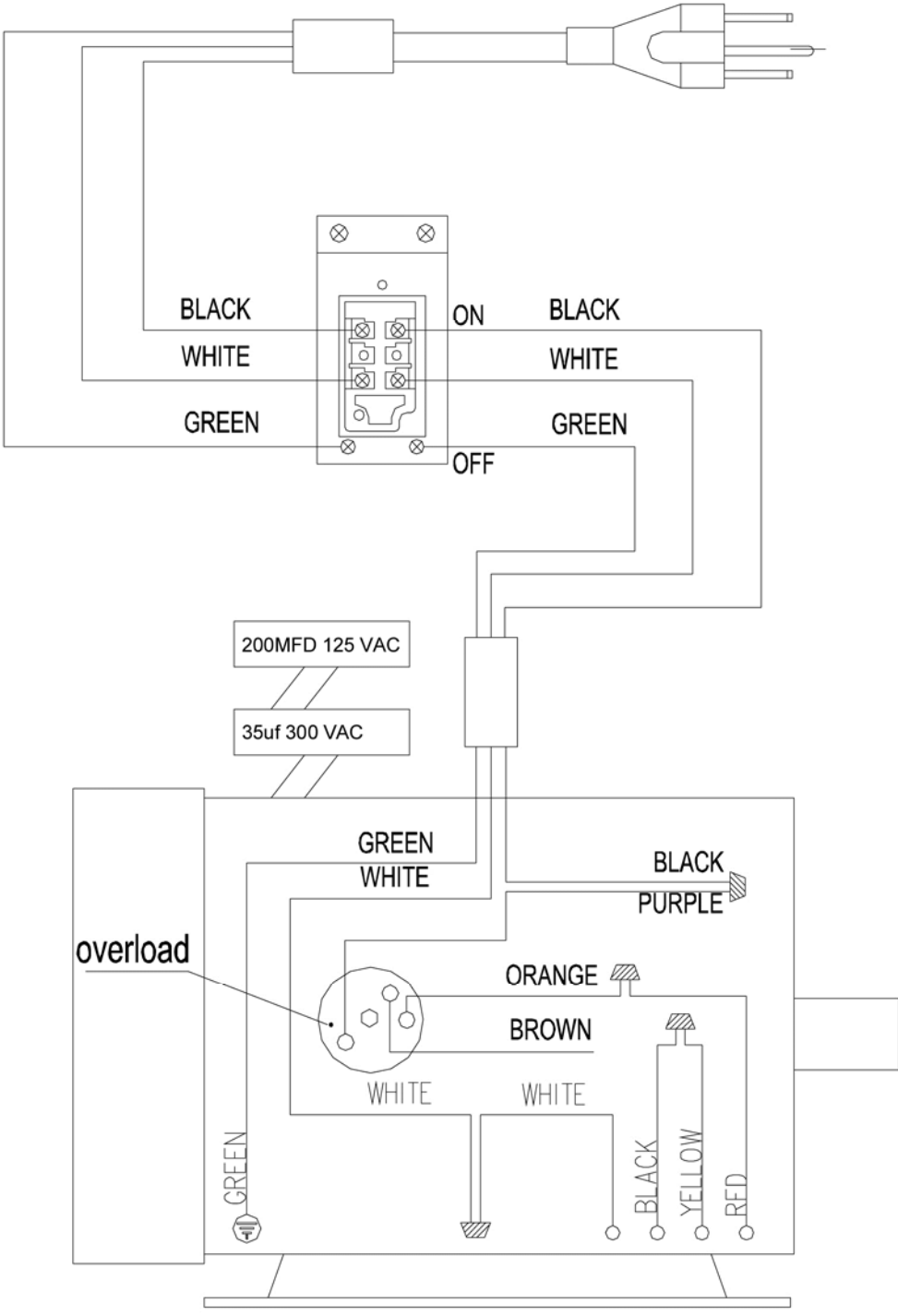



427 New Sanford Road
LaVergne, Tennessee 37086
Phone: 800-274-6848
www.jettools.com